

SCHOOL DISTRICT OF COLBY EDUCATION CENTER

DR. STEVEN KOLDEN, SUPERINTENDENT

FINANCIAL AFFAIRS COMMITTEE MEETING

**MONDAY, DECEMBER 18, 2017
6:00 PM
COLBY DISTRICT EDUCATION CENTER**

OPEN MEETING

AGENDA

- 1) Review Invoices & Receipts

Committee Members Include: Seth Pinter, Chair
Eric Elmhorst
Jennifer Lopez

SCHOOL DISTRICT OF COLBY EDUCATION CENTER

Dr. Steven Kolden, Superintendent

REGULAR SCHOOL BOARD MEETING

Monday, December 18, 2017 – 6:30 PM

Colby District Education Center - Door 19

MEETING NORMS

- *The Board President will actively monitor our interactions.*
- *We will actively listen and not interrupt others.*

AGENDA:

1. CALL TO ORDER / ROLL CALL
2. PLEDGE OF ALLEGIANCE
3. NOTICE OF POSTING
4. PUBLIC PARTICIPATION
5. BOARD COMMENDATIONS (If Any)
6. INFORMATION ITEMS:
 - 6.01 Correspondence (If Any)
 - 6.02 Student Board Representative Report
 - 6.03 Superintendent's Report – Steve Kolden [Candidacy Filing Reminder, WASB State Convention, HS Theatre Lighting/Curtains Progress, ALICE Training Update, Phone Emergency Updates, Welding Simulator]
 - 6.04 Strategic Planning Progress Monitoring – Date reminder; January 24, February 8, February 22, & March 15 (if needed)
7. CONSENT AGENDA
 - 7.01 Minutes from the November 20, 2017 Regular Board Meeting
 - 7.02 Requests for Out-of-State Travel
 - 7.02-1 FFA Request to travel to St. Paul, MN for World's Toughest Rodeo - January 6, 2018
 - 7.02-2 Middle School Choir & Show Choir Request to travel to Gurnee, IL - May 11 & 12, 2018
 - 7.03 Approve Board Member Attendance and Expenses for Travel Outside the District at Meetings Other Than Regular, Special or Committee Meetings (If Any)
 - 7.04 Staff Resignations/Retirements/Leave Requests (If Any)
 - 7.05 Personnel – Transfers/New Hires
 - 7.05-1 Hire of Jill Spindler, Assistant Drama Advisor
 - 7.05-2 Hire of Rick Melcher, Varsity Golf Coach
 - 7.05-3 Transfer of Hugh Feirer, Colby Middle School Day Custodian
 - 7.05-4 Transfer of Christina Gregory, Colby High School Evening Custodian
 - 7.05-5 Other Transfers/New Hires
 - 7.06 Awards, Donations and Gifts to the School District of Colby (If Any)
8. REGULAR BUSINESS – CONSIDERATION OF:
 - 8.01 Agenda Items Moved From Consent Agenda
 - 8.02 Recommendation of Finance Committee
9. DISCUSSION INFORMATION
 - 9.01 Consideration of Reports of Board Members' Attendance at Seminars and Workshops
 - 9.02 2017-18 Budget Update
 - 9.03 2017 Auditors Report
 - 9.04 Staffing for 2018-19

10. ACTION INFORMATION
 - 10.01 Agenda Items Moved From Consent Information
 - 10.02 WASB Delegate Resolutions
 - 10.03 Approve ACP (Academic and Career Planning) Plan
 - 10.04 Discuss / Approve Bid Documents for HS/MS Parking Lot
 - 10.05 Discuss / Approve Bid Documents for MS Roof
 - 10.06 Discuss / Approve SECOND Reading of Extra Curricular Advisor Position for Educators Rising (7 pts.)
 - 10.07 Discuss / Approve SECOND Reading of Revision to Handbook Part II – Section 8 Post-Employment Benefits
 - 10.08 Discuss / Approve SECOND Reading of revision to Handbook Appendix Part I – Extra Duty Wage Schedule
11. CONVENE TO CLOSED SESSION PER WISCONSIN STATUTES 19.85 (1) FOR THE PURPOSES OF:
 - c) Considering employment, promotion, compensation or performance evaluation data of any public employee over which the governmental body has jurisdiction or exercises responsibility.
 - e) Deliberating or negotiating the purchasing of public properties, the investing of public funds, or conducting other specified public business, whenever competitive or bargaining reasons require a closed session. The Board will consider:
 - 11.01 Agenda Items Moved From Consent Information
 - 11.02 Agenda Items Moved From Action Information
 - 11.03 Superintendent Evaluation
 - 11.04 Administrative Contracts - Renewal
 - 11.05 Discuss Individual Contract Non-renewal
 - 11.06 Reconvene in Open Session
12. THE BOARD WILL RECONVENE IN OPEN SESSION IMMEDIATELY UPON COMPLETING THE CLOSED SESSION TO TAKE ACTION, IF NECESSARY, ON SELECTED MATTERS DISCUSSED IN CLOSED SESSION.
13. IDENTIFY ITEMS FOR NEXT AGENDA
 - 13.01 Schedule Meetings:
 - 13.01-1 Financial Affairs Committee Meeting – January 15, 2018 @ 6:00 PM
 - 13.01-2 Regular Board of Education Meeting – January 15, 2018 @ 6:30 PM
 - 13.01-3 Facilities and Transportation Committee Meeting –
 - 13.01-4 Personnel Committee Meeting –
 - 13.01-5 Policy and Curriculum Committee Meeting –
 - 13.01-6 Strategic Planning Meetings – January 24, February 8, 22 and March 15 @ 6:30 PM
14. ADJOURNMENT



THE LINCOLN *VRTEX* SIMULATOR WELDING EXPERIENCE

IS COMING TO COLBY HIGH SCHOOL

Wednesday, January 24, 2018

- Try out your welding skills in a fun, relaxed environment!
- Have a fun friendly competition with your friends!
- The top two welders from your school will be asked to compete in a county wide weld competition at *participating companies!*
- Win prizes for yourself and your school!***



Presented by 

SCHOOL DISTRICT OF COLBY EDUCATION CENTER

Dr. Steven Kolden, Superintendent

January 5, 2018

RE: District Strategic Planning Invitation

Dear,

I am writing to extend an invitation to be a part of the Stakeholder-Driven Strategic Planning process for the Colby School District.

We are seeking community leaders, former Board members, elected officials, clergy, business leaders and individuals with an interest in local public education. While we will welcome and encourage anyone to attend, we are seeking a “core team” of individuals that are willing to commit three or four evenings, for a maximum of 2 hours each night to help us review and revise our long range vision and goals. We are seeking local stakeholders to provide us with that “big picture” and periodically review our progress. Core Team Volunteers are not expected to participate in the strategic planning process after the plan is drafted and presented to the school board. However, volunteers may continue to participate actively in school district affairs through a wide variety of other means.

Core Team Volunteers will be asked to:

- a. Attend up to 4 community meetings, at which strategic planning for the school district will be discussed. Each meeting will last no longer than 2 hours.
- b. Actively participate in each of the community meetings.
- c. Help communicate the strategic planning process and its products to the rest of the community.

Scheduled dates for Strategic Planning are January 24th, February 8th, February 22nd and March 15th (if needed). All meetings will begin at 6:30 PM

IF YOU ARE WILLING TO PARTICIPATE, please contact Kristen Seifert at kseifert@colby.k12.wi.us OR 715.223.2301, ext. 2 to confirm your participation. We hope you are able to join us for this planning process.

On Behalf of the Board of Education,

Steve Kolden
Superintendent

REGULAR MEETING MINUTES
BOARD OF EDUCATION – SCHOOL DISTRICT OF COLBY
MONDAY, NOVEMBER 20, 2017
COLBY DISTRICT/EDUCATION CENTER

The Regular School Board Meeting on November 20, 2017 was called to order at 6:35 PM at the Colby District Education Center by Board President, William Tesmer. Members present were: Jean Schmitt, William Tesmer, Lavinia Bonacker, Seth Pinter, Eric Elmhurst, Jennifer Lopez and Cheryl Ploeckelman. Also present were Superintendent Steven Kolden, Audra Brooks, and Carley Elmhurst.

The meeting notice was posted according to the requirements of the open meetings law.

The board presented Board Commendations for Samuel Krause and Nathan Meyer who were named to the WFCAC Academic All-State Team.

The Board received a thank you from the Bill Shanks Family and the Pauline Clark Family.

Carley Elmhurst, Student Board Representative updated the board: Student Council is planning the Angel Tree project and Hats On Day; SADD joined the middle school to watch the movie Wonder and had debriefing the following day; FBLA Candy Cane sale will be starting soon; FFA just finished their fruit sale and upcoming activities include the Speaking Contest and a Rodeo Trip; NHS Candy Cane sale will begin soon; Chess Club has started playing; FCCLA will be helping with Dinner with Santa on December 16; SMACC is starting debates; Forensics has begun; Winter Sports have started and they are all in their 2nd or 3rd week; Choir; Christmas concert is on December 4, the Coalition had their performance, the Madrigal dinner will be on December 9 and 10; Band is doing a Blanket Fundraiser and their Christmas concert is on December 11.

Mr. Kolden updated the Board on the BOE election/paperwork; District and School Report Cards; “Grow Your Own” and Educators Rising information; Medford Legislative Session on March 5 – Mr. Kolden will compile anything you have and send to Medford.

Mr. Kolden discussed the planning of the Strategic Plan – Greg Corning, Superintendent from Mondovi will facilitate Colby’s Strategic Plan. The following dates have been set:

January 24 @ 6:30 PM
February 8 @ 6:30 PM
February 22 @ 6:30 PM
March 15 (if needed) @ 6:30 PM

Motion by Mrs. Lopez, seconded by Mrs. Bonacker to approve the consent agenda as presented:
Minutes from the October 16, 2017 Regular Board Meeting and the minutes from the November 8, 2017 Special Joint Board meeting
WASB Board meetings and CESA 10 Board of Control meetings will be reimbursed for expenses.
Resignation of Brian Bruesewitz, JV Boys Basketball Coach
Retirement of DuWayne Sheets, Middle School Custodian
Hire of Tim Stewart, C Team Boys Basketball Coach
Hire of Nancy Brown, Special Education Transportation Aide – 5 hrs/day
Hire of Michael Collins, Special Education Transportation Aide – 5 hrs/day
Accept with appreciation; Welder donated by A & B Processing
Accept with appreciation; Serpentine belt display donated by D & A Automotive

Voice vote – motion carried.

Motion by Mrs. Lopez, seconded by Mr. Pinter to approve the receipts and invoices as presented. Voice vote – motion carried.

Financial Report

TOTAL REVENUE – OCTOBER		\$ 51,196.38
NICOLET NATIONAL BANK-REFERENDUM APPROVED ACCT.	1022-1025	\$ 463,209.32
NICOLET NATIONAL BANK-PENSION ACCT.	1032	\$ 3,201.46
NICOLET NATIONAL BANK-MANUAL CHECKS	1-4 & 2263-2271	\$ 139,447.95
FORWARD FINANCIAL BANK-MANUAL CHECKS	261-263	\$ 10,704.13
REGULAR CHECKS	31779-31818	\$ 11,605.73
DIRECT DEPOSITS	900068264-900068582	\$ 288,870.85
WIRE TRANSFERS	201700012-201700014	\$ 67,582.71
ADVANTAGE BANK-REGULAR CHECKS	74343-74561	\$ 664,013.43
TOTAL CHECKS TO BE APPROVED		\$ 1,648,635.58

Mr. Kolden and the board discussed the recent WIRSA conference that Mrs. Ploeckelman, Mr. Tesmer, and Mr. Kolden attended and the Veterans Day Program.

Mr. Kolden reviewed the 2017-18 budget update.

Mr. Kolden and the board discussed the Joint School Board meeting with Abbotsford and will review this goal in the upcoming Strategic Plan.

Motion by Mrs. Bonacker, seconded by Mrs. Ploeckelman to approve the creation of an extracurricular Educators Rising Advisor position at 7 points. Voice Vote – motion carried.

Motion by Mr. Elmhorst, seconded by Mrs. Bonacker to approve the purchase of replacement Pits, Standards, and Crossbar for track as presented. Voice Vote – motion carried.

Motion by Mr. Elmhorst, seconded by Mrs. Bonacker to approve proposal 1 of the 2018-19 school calendar. Voice vote – motion carried.

Motion by Mr. Elmhorst, seconded by Mrs. Lopez to approve the RVA Membership for 2018-19. Voice vote – motion carried.

Motion by Mrs. Bonacker, seconded by Mr. Elmhorst to approve the first reading of revision to Handbook Part II – Section 8 Post-Employment Benefits as recommended by the personnel committee. Voice Vote – motion carried.

Motion by Mrs. Bonacker, seconded by Mrs. Lopez to approve the first reading of revision to Handbook Appendix Part I – Extra Duty Wage Schedule as recommended by the personnel committee. Roll Call vote – Motion carried 6-0-1; Yes – Mrs. Lopez, Mr. Pinter, Mr. Elmhorst, Mrs. Schmidt, Mrs. Bonacker, Mrs Ploeckelman; No – None; Abstain – Mr. Tesmer.

Motion by Mr. Elmhorst, seconded by Mrs Lopez, to adjourn the meeting. Voice vote - motion carried. Meeting adjourned at 7:40 PM.

Respectfully Submitted:

Eric Elmhorst, Clerk

Audra Brooks, Reporting Secretary

OUT-OF-STATE FIELD TRIP

Teacher/Advisor: Taylor Ensign & Jenessa Freidhof

Group: FFA

Destination: World's Toughest Rodeo (St. Paul, MN)

Date of Trip: January 6, 2018

Purpose of Trip: This is an opportunity for FFA members to be rewarded for their involvement as well as give them opportunities to meet and interact with members from across MN and WI. Please see attached letter

Number of Students Attending: 45 members

Number of Adults/Chaperones: 3 chaperones, 2 advisors (5 total)

District Expenses: None

Non-District Expenses: Students help to pay their way. All other expenses come from the FFA activity account

Administrative Approval: Maria Dredlich

Colby FFA Chapter

Colby High School • 705 North Second Street • Colby, WI 54421
(715) 223 – 2338 • Ext. 5147



Bailey Krause
President

Devon Weiland
Vice President

Katerina Kolzow
Secretary

Brittney Zawislan
Treasurer

Keira Kapfhamer
Reporter

Kyle Finke
Sentinel

Jenessa Freidhof
Advisor

Taylor Ensign
Advisor

November 28, 2017

Dr. Kolden and School Board Members,

I am writing to request permission for 45 FFA members, 3 chaperones, and 2 advisors to attend the World's Toughest Rodeo on Saturday, January 6, 2018 in St. Paul, MN. The World's Toughest Rodeo is an event hosted by the Excel Energy Center specifically for FFA members across Wisconsin and Minnesota.

The Colby FFA members will be traveling to the World's Toughest Rodeo on a coach bus, chaperoned by advisors Jenessa Freidhof and Taylor Ensign as well as by multiple parents who look forward to this event each year. We are planning to leave the school at 6:30 am on January 6th and returning on January 7th by 1:00 am.

While on the trip, our FFA members will have the opportunity to meet other FFA members from across the states of Wisconsin and Minnesota, enjoy a movie in a cinema featuring a mega screen and dreamloungers, experience the many different cultures at the Mall of America, and end the day with an exciting piece of agriculture that many students have not experienced before; a PBR rodeo.

Again, I am asking permission to share a great opportunity and reward with these outstanding FFA members outside of the state of Wisconsin. The skills gained, knowledge acquired, and enthusiasm brought back will have a positive impact on all of us. Please consider this request. If you have any questions, comments or concerns regarding this matter, please feel free to contact me.

Sincerely,

Taylor Ensign
Colby Agriculture Education Instructor
Colby FFA Advisor
(715) 223-2338 Ext. 5147

OUT-OF-STATE FIELD TRIP

Teacher/Advisor Kevin J. Spindler - Colby Middle School Choir
Group Colby Middle School Choir & Show Choir
Destination Gurnee, IL, Music In the Parks Festival, Great America, Medieval Times
Date of Trip May 11 & 12, 2018 Leave 7:30 AM ^(May 11) Return May 12 @ 11:30 pm

Purpose of the trip Music Festival Competition; Watch Live Dinner Theatre;
Performance of Medieval Times (Live Jousting); attend Six Flags
Great America after Choir competition.

Number of students attending 50

Number of adults/chaperones 4-5 chaperones

District Expenses 4 School Employees for Substitute Teachers only for May 11th

Non-District Expenses all students pay for individual trip; fundraising
helps offset costs of trip

Administrative Approval 

To: Dr. Steve Kolden, District Administrator , and the Colby School Board

From: Kevin J. Spindler, Middle School Choir Teacher

Re: Information regarding an Out-of-State Trip

The Colby Middle School Choir is looking for approval of a choir trip to Gurnee, IL on May 11 and 12, 2018. The Trip itinerary includes going to Medieval Times Dinner Theatre & Tournament, participation in the Great American Parks Festival performance, one night's accommodation at the Holiday Inn, and admission to Six Flags Great America Theme Park. The cost of the trip is \$222 per student/chaperone. The cost will also include busing expense. There is about 50-60 students wanting to attend along with Mr. Spindler, and 3 more chaperones. The Middle School Choir has been fundraising to help offset the cost of the trip per student. Last year, along with previous year's, the Colby Middle School Choir have profited between \$2700-\$3000. We are asking for the 4 school chaperones (included is Mr. Spindler as one of the 4 being requested) that we have used every year. This would entail substitute teachers for one day of service, please.

In the past years, the trip was well-planned, well-chaperoned, and our students exceeded our expectations with regards to their behavior, performance, and attitude. The choir students have been reaching goals they have set for themselves from the beginning of the year. This trip would give our students the challenge to meet those goals. What these students gain from these trips are great musical and educational experiences that enhance their personal performance levels. Please contact me with any questions or concerns you may have. (715-223-2338 ext. 4249)
Thank-you for your time.

Enclosed is the proposed itinerary.

Kevin J. Spindler

Colby High School /Middle School Vocal Music Teacher Grades 6-12

May 11, 2018 (Friday)

- 7:45am Arrive at School (Go to Choir Room)
- 8:15am Load Buses in front of school
- 8:30am Leave Colby Middle School (Bye.... Colby, Wisconsin)
- 11:00am Stop and eat for lunch (**students pay for their own**) Fond du lac, WI
- 11:45pm Leave for Jelly Belly Factory
- 1:30pm Arrive at Jelly Belly Factory
- 1:45pm Jelly Belly Factory Tour
- 3:00pm Leave for Gurnee Mills Outlet Mall
- 3:15pm Gurnee Mills Outlet Mall (Shop and Eat Supper)
- 5:00pm Load Buses and Leave for Holiday Inn
- 5:15pm Arrive at the Hotel-check in Holiday Inn -Gurnee, IL
- 5:45pm Load Buses and Leave for Music in the Parks Festival **Be on the bus at 5:45pm please!**
- 6:00pm Arrive at Music In the Parks Festival----Unload!
- 6:30pm Warm-up MS Mixed Choir
- 7:00pm MS Mixed Choir Performance (included- Music in the Parks Festival)
- 7:20pm Colby Crew II (MS Show Choir) get changed/ready! Rest of choir watch performances
Warm-up Colby Crew II MS Show Choir
- 7:40pm MS Colby Crew II Show Choir Performance (included)
- 8:00pm Pack up and LOAD to go to the Holiday Inn!
- 8:30pm Arrive at Holiday Inn-Gurnee ***Please RESPECT the RULES!***
******Remember WE DO NOT OWN HOLIDAY INN. Consequence: We LOSE time at Great America!***
Swim/ Relax
- 10:30 pm LIGHTS OUT! (Mr. Spindler and Chaperones check rooms)

May 12, 2018 (Saturday)

- 7:00-7:30am Wake-up calls go out (each room sets up their own) (EAT AT HOTEL)
- Chaperones are to check the rooms
- 9:00-9:15am Load Bus & Depart for Six Flags Great America (ticket included)
- 9:45am Arrive at Six Flags Great America- Lunch on their own (not-included)
- 3:00pm Exit Six Flags Great America Be on the BUS by 3:00-3:05 PLEASE! We do not want to be late!
- 3:15pm Depart for Medieval Times Dinner & Tournament ***We need to beat the traffic!**
- 4:15 pm Arrive at Medieval Times Dinner & Tournament
- 4:30 pm Medieval Times Show Begins - **Meal included**
- Live Jousting- Every group has a knight to cheer on
- Souvenirs to buy if you want to- ***Jolly good time sport!***
- 6:30 pm Load Buses After Show for Colby!!!
- 11:30/12:00am Arrive back at Colby (depending on traffic)

SCHOOL DISTRICT OF COLBY EDUCATION CENTER

Dr. Steven Kolden, Superintendent

Request To: Hire Transfer Expand Employment
(Please check appropriate assignment)

Purpose: To request approval for persons who have been transferred to a new position, have current assignment expanded, or tendered employment. In order to insure compliance with federal and state laws, clearance must be obtained from the human resources director prior to the person reporting to work.

Spindler, Jill
Employee's Name: Last, First

Assistant Drama
Position and Building Location

FTE: _____ Continuing Position? Yes No

(If no, Start and End Dates) _____ through _____

Administration Teacher Long Term Sub Instructional Aide Clerical Maintenance Food Service Coach
 Other: Assistant Club Advisor

Work schedule for hourly staff (to include scheduled lunch break) _____ a.m. To _____ p.m.

Desired start date: _____ Is this a support staff position? Yes No If yes, please attach work calendar.

Does this position require a substitute? Yes No Work Permit Attached (If Needed) Yes No

Indicate all account number(s) and percent of time for each account number to charge wages to (including grant accounts)

Hire Requested by:

Maura Diedrich
Immediate or Program Supervisor's Signature

12-8-17
Date

S. Kolden
Superintendent's Signature

12-8-17
Date

Reason for position vacancy:

Retirement

Date position was vacated:

June 29, 2017

Number of candidate files:

2

Number of candidates after screening:

2

Number of candidates interviewed:

2

Person vacating position:

Kathy Bay

Recruitment area:

internal

Person(s) doing screening:

Marcia Diedrich

Person(s) doing interviewing:

Marcia Diedrich

Candidate Biography / Resume & Application Attached

Employee needs the following:

Web Page Access Email Phone Extension
 Student Information System Lunch Account FOB/Key

OFFICE USE ONLY

SALARY: _____

CODE: _____

PAYROLL
 BOOKKEEPER
 ACCT. PAYABLE

505 WEST SPENCE ST. • P.O. BOX 139 • COLBY, WI 54421-0139
PHONE 715.223.2301 • FAX 715.223.4539
SKOLDEN@COLBY.K12.WI.US

SCHOOL DISTRICT OF COLBY EDUCATION CENTER

Dr. Steven Kolden, Superintendent

Request To: Hire Transfer Expand Employment
(Please check appropriate assignment)

Purpose: To request approval for persons who have been transferred to a new position, have current assignment expanded, or tendered employment. In order to insure compliance with federal and state laws, clearance must be obtained from the human resources director prior to the person reporting to work.

Melcher, Rick Head Golf Coach
 Employee's Name: Last, First Position and Building Location

FTE: 1.0 Continuing Position? Yes No

(If no, Start and End Dates) _____ through _____

Administration Teacher Long Term Sub Instructional Aide Clerical Maintenance Food Service Coach
 Other: _____

Work schedule for hourly staff (to include scheduled lunch break) _____ a.m. To _____ p.m.

Desired start date: _____ Is this a support staff position? Yes No If yes, please attach work calendar.

Does this position require a substitute? Yes No Work Permit Attached (If Needed) Yes No

Indicate all account number(s) and percent of time for each account number to charge wages to (including grant accounts)

Hire Requested by: [Signature] 11-22-17
 Immediate or Program Supervisor's Signature Date
[Signature] 11-27-17
 Superintendent's Signature Date

Reason for position vacancy:
Resignation / Retirement
Date position was vacated:
Summer 2017
Number of candidate files:
1
Number of candidates after screening:
1
Number of candidates interviewed:
1

Person vacating position:
Jeff Rosemeyer
Recruitment area:
Internal
Person(s) doing screening:
Jim Hagen
Person(s) doing interviewing:
Jim Hagen

Candidate Biography / Resume & Application Attached

Employee needs the following: He already has all of this!
 Web Page Access Email Phone Extension
 Student Information System Lunch Account FOB/Key

OFFICE USE ONLY
 SALARY: _____
 CODE: _____
 PAYROLL
 BOOKKEEPER
 ACCT. PAYABLE

SCHOOL DISTRICT OF COLBY EDUCATION CENTER

Dr. Steven Kolden, Superintendent

Request To: Hire **Transfer** Expand Employment
(Please check appropriate assignment)

Purpose: To request approval for persons who have been transferred to a new position, have current assignment expanded, or tendered employment. In order to insure compliance with federal and state laws, clearance must be obtained from the human resources director prior to the person reporting to work.

Feiver Hugh _____ M.S. Day Custodian _____
Employee's Name: Last, First Position and Building Location

FTE: YES Continuing Position? Yes No

(If no, Start and End Dates) _____ through _____

Administration Teacher Long Term Sub Instructional Aide Clerical Maintenance Food Service Coach
 Other: Custodian

Work schedule for hourly staff (to include scheduled lunch break) 6:30 a.m. To 3:00 p.m.

Desired start date: Dec. 11, 2017 Is this a support staff position? Yes No If yes, please attach work calendar.

Does this position require a substitute? Yes No Work Permit Attached (If Needed) Yes No

Indicate all account number(s) and percent of time for each account number to charge wages to (including grant accounts)

Hire Requested by:

Dennis Wenzel
Immediate or Program Supervisor's Signature

Dec. 11, 2017
Date

S. Kolden
Superintendent's Signature

12-11-17
Date

Reason for position vacancy: retirement

Person vacating position: DuWayne Shoets

Date position was vacated: Dec. 8, 2017

Recruitment area: H.S.

Number of candidate files: 2

Person(s) doing screening: Dennis Wenzel

Number of candidates after screening: 2

Person(s) doing interviewing: Dennis Wenzel

Number of candidates interviewed: 2

Candidate Biography / Resume & Application Attached

Employee needs the following:

Web Page Access Email Phone Extension
 Student Information System Lunch Account FOB/Key

OFFICE USE ONLY	
SALARY:	_____
CODE:	_____
<input type="checkbox"/>	PAYROLL
<input type="checkbox"/>	BOOKKEEPER
<input type="checkbox"/>	ACCT. PAYABLE

SCHOOL DISTRICT OF COLBY EDUCATION CENTER

Dr. Steven Kolden, Superintendent

Request To: Hire Transfer Expand Employment
(Please check appropriate assignment)

Purpose: To request approval for persons who have been transferred to a new position, have current assignment expanded, or tendered employment. In order to insure compliance with federal and state laws, clearance must be obtained from the human resources director prior to the person reporting to work.

Gregory Christina
Employee's Name: Last, First

Evening Custodian H.S.
Position and Building Location

FTE: ✓ Continuing Position? Yes No

(If no, Start and End Dates) _____ through _____

Administration Teacher Long Term Sub Instructional Aide Clerical Maintenance Food Service Coach
 Other: Custodian

Work schedule for hourly staff (to include scheduled lunch break) 3:15 a.m. To 11:45 p.m.

Desired start date: Dec. 18, 2017 Is this a support staff position? Yes No If yes, please attach work calendar.

Does this position require a substitute? Yes No Work Permit Attached (If Needed) Yes No

Indicate all account number(s) and percent of time for each account number to charge wages to (including grant accounts)

Hire Requested by:

Dennis M. Ward
Immediate or Program Supervisor's Signature

Dec. 15, 2017
Date

Steven Kolden
Superintendent's Signature

12-15-17
Date

Reason for position vacancy:

Person vacating position:

Date position was vacated:

Recruitment area:

Number of candidate files:

Person(s) doing screening:

Number of candidates after screening:

Person(s) doing interviewing:

Number of candidates interviewed:

Candidate Biography / Resume & Application Attached

Employee needs the following:

Web Page Access Email Phone Extension
 Student Information System Lunch Account FOB/Key

OFFICE USE ONLY

SALARY: _____

CODE: _____

PAYROLL
 BOOKKEEPER
 ACCT. PAYABLE

505 WEST SPENCE ST. • P.O. BOX 139 • COLBY, WI 54421-0139
PHONE 715.223.2301 • FAX 715.223.4539
SKOLDEN@COLBY.K12.WI.US

FINANCIAL REPORT
BOARD OF EDUCATION MEETING
December 18, 2017

TOTAL REVENUE -
November \$ 289,142.68

NICOLET NATIONAL BANK -
REFERENDUM APPROVED ACCOUNT 1026-1027 \$265,830.90
PENSION ACCOUNT 1033 \$3,444.65

NICOLET NATIONAL BANK -
MANUAL CHECKS 5-8 \$120,677.02
MANUAL CHECKS 2272-2280 \$ 18,284.48

FORWARD FINANCIAL
MANUAL CHECKS 264-266 \$ 10,900.44
REGULAR CHECKS 31819-31844 \$ 10,909.48
DIRECT DEPOSITS 900068583-900068907 \$ 277,061.27
WIRE TRANSFERS 201700015-201700018 \$ 84,644.52

ADVANTAGE BANK-
REGULAR CHECKS 74562-74590 \$ 21,299.55
74591-74603 \$ 12,567.19
74604-74640 \$ 21,979.15
74641-74642 \$ 2,240.43
74643-74650 \$ 1,310.15
74651-74702 \$ 322,741.76

TOTAL CHECKS TO BE APPROVED \$1,173,890.99

DECEMBER 2017 BOARD REPORT

FORWARD FINANCIAL:

MANUAL CHECKS: 264-266 = \$10,900.44

WIRE TRANSFERS: 201700015-201700018 = \$84,644.52

DIRECT DEPOSITS: 900068583 – 900068907 = \$277,061.27

REGULAR CHECKS: 31819-31844 = \$10,909.48

NICOLET NATIONAL BANK:

MANUAL CHECKS: 5 – 8 = \$120,677.02

MANUAL CHECKS: 2272-2280 = \$18,284.48

PENSION ACCOUNT: 1033 = \$3444.65

CAPITAL PROJECT FUND: 1026-1027 = \$265,830.90

FORWARD FINANCIAL:

MANUAL CHECKS: \$10,900.44

264	GREAT WEST	M	11/10/2017	\$4,270.70
265	GREAT WEST	M	11/24/2017	\$4,220.98
266	AMERICAN FUNDS SERVICE COMPANY	M	11/10/2017	\$2,408.76

WIRE TRANSFERS: \$84,644.52

201700015	WISCONSIN RETIREMENT SYSTEM	W	10/13/2017	\$22,031.73
201700016	WISCONSIN RETIREMENT SYSTEM	W	10/27/2017	\$20,631.16
201700017	WISCONSIN RETIREMENT SYSTEM	W	11/10/2017	\$21,538.33
201700018	WISCONSIN RETIREMENT SYSTEM	W	11/24/2017	\$20,443.30

DIRECT DEPOSITS: \$277,061.27

900068583-900068739 = \$139,205.02

900068740-900068907 = \$137,856.25

REGULAR CHECKS: \$10,909.48

31819	PAYROLL CHECK	R	11/24/2017	\$175.24
31820	PAYROLL CHECK	R	11/24/2017	\$73.65
31821	PAYROLL CHECK	R	11/24/2017	\$26.32
31822	PAYROLL CHECK	R	11/24/2017	\$17.54
31823	PAYROLL CHECK	R	11/24/2017	\$17.54
31824	PAYROLL CHECK	R	11/24/2017	\$17.54
31825	PAYROLL CHECK	R	11/24/2017	\$13.16
31826	PAYROLL CHECK	R	11/24/2017	\$17.54
31827	PAYROLL CHECK	R	11/24/2017	\$17.54
31828	PAYROLL CHECK	R	11/24/2017	\$87.73
31829	PAYROLL CHECK	R	11/24/2017	\$219.33
31830	PAYROLL CHECK	R	11/24/2017	\$175.46
31831	PAYROLL CHECK	R	11/24/2017	\$87.73
31832	PAYROLL CHECK	R	11/24/2017	\$24.94
31833	IDEA FOUNDATION OF COLBY, INC	R	11/24/2017	\$70.00
31834	WI SUPPORT COLLECTIONS FUND	R	11/24/2017	\$511.38
31835	PAYROLL CHECK	R	12/8/2017	\$175.24
31836	PAYROLL CHECK	R	12/8/2017	\$753.58
31837	PAYROLL CHECK	R	12/8/2017	\$706.48
31838	PAYROLL CHECK	R	12/8/2017	\$87.73
31839	PAYROLL CHECK	R	12/8/2017	\$447.43
31840	WI SUPPORT COLLECTIONS FUND	R	12/8/2017	\$511.38
31841	AMERIPRISE FINANCIAL SERVICES	R	12/8/2017	\$975.00
31842	THRIVENT FINANCIAL	R	12/8/2017	\$2,325.00
31843	WEA MEMBER BENEFITS	C	12/8/2017	\$0.00
31844	WEA MEMBER BENEFITS	R	12/8/2017	\$3,375.00

NICOLET NATIONAL BANK:

MANUAL CHECKS: \$120,677.02

5	NICOLET NATIONAL BANK	M	11/10/2017	\$53,053.13
6	NICOLET NATIONAL BANK	M	11/24/2017	\$49,944.75
7	WI DEPT OF REVENUE	M	11/10/2017	\$9,087.56
8	WI DEPT OF REVENUE	M	11/24/2017	\$8,591.58

MANUAL CHECKS: \$18,284.48 (MUNICIPAL CHECKING 5)

2272	EMPLOYEE BENEFITS CORPORATION	M	11/2/2017	\$481.41
2273	EMPLOYEE BENEFITS CORPORATION	M	11/16/2017	\$1,481.88
2274	EMPLOYEE BENEFITS CORPORATION	M	11/27/2017	\$3,305.34
2275	EMPLOYEE BENEFITS CORPORATION	M	11/30/2017	\$3,705.35
2276	EMPLOYEE BENEFITS CORPORATION	M	11/10/2017	\$1,627.37
2277	EMPLOYEE BENEFITS CORPORATION	M	11/24/2017	\$1,627.37
2278	EMPLOYEE BENEFITS CORPORATION	M	11/30/2017	\$97.50
2279	WEA TRUST ADVANTAGE	M	11/10/2017	\$2,976.27
2280	WEA TRUST ADVANTAGE	M	11/24/2017	\$2,981.99

PENSION ACCOUNT: \$3,444.65

1033	VOYA FINANCIAL	R	12/8/2017	\$3,444.65
------	----------------	---	-----------	------------

CAPITAL PROJECTS FUND: \$265,830.90

1026	COMPLETE CONTROL, INC.	R	12/8/2017	\$153,999.50
1027	MIRON CONSTRUCTION CO., INC.	R	12/8/2017	\$111,831.40

BATCH	DESCRIPTION	FISCAL YEAR	POST DATE	BATCH ORIGIN	STATUS
CASH	NOVEMBER 2017 CASH REPORT	2017-2018	11/30/2017	Batch Entry	Batch

BANK	LINE	NAME/PROJ	DESCRIPTION/REFERENCE	ADD'L DSC/PAY TYPE	ACCOUNT/QUICK KEY	RECEIPT#	ENTRY DT	DEBIT AMOUNT	CREDIT AMOUNT
BNK2	1		HIGLEY		SHOW CHOIR BUS FEE 10 R 800 292 163314 000	780569	11/06/17	0.00	50.00
					CASH				
BNK2	2		TODAHL		SHOW CHOIR BUS FEE 10 R 800 292 163314 000	780570	11/06/17	0.00	50.00
					CHECK 1010				
BNK2	3		KLEPARSKI		SHOW CHOIR BUS FEE 10 R 800 292 163314 000	780571	11/06/17	0.00	50.00
					CHECK 2323				
BNK2	4		KLEPARSKI		CLASS DUES / JE & T 10 R 800 292 500000 000	7805711	11/06/17	0.00	5.00
					CHECK 2323				
BNK2	5		COUNTRY PURE FOODS		REBATE 50 R 800 259 257220 000	780572	11/06/17	0.00	30.00
					CHECK 329079				
BNK2	6		LUEDECKE		DONATION / BLESSING 21 R 800 291 500000 941	780573	11/06/17	0.00	20.00
					CHECK 1316				
BNK2	7		STUDENTS		CHROMEBOOK FEES 10 R 800 292 266000 000	780574	11/06/17	0.00	60.00
					CASH				
BNK2	8		WI DPI		COMMODITY CHARGE 50 E 800 387 257220 000	780575	11/06/17	3,530.18	0.00
					EFT				
BNK2	9		WI DPI		SEPTEMBER CLAIM 50 R 800 717 257220 000	780575	11/06/17	0.00	29,010.67
					EFT				
BNK2	10		WI DPI		SEPTEMBER CLAIM 50 R 800 717 257225 000	780575	11/06/17	0.00	6,025.13
					EFT				
BNK2	11		STUDENT		CHROMEBOOK DAMAGE / 10 R 800 292 266000 000	780576	11/07/17	0.00	7.53
					CHECK 2451				
BNK2	12		STUDENTS		ATHLETIC FEES 10 R 800 292 162000 000	780577	11/07/17	0.00	250.00
					OTHER TYPE				
BNK2	13		STUDENT		SHOW CHOIR BUS FEE 10 R 800 292 163314 000	780578	11/07/17	0.00	10.00
					CASH				
BNK2	14		ADMISSIONS - SECTIONALS		CASH \$2414 CHECK OF 10 R 800 271 162000 000	780579	11/08/17	0.00	2,425.00
			SWIM		OTHER TYPE				
BNK2	15		RAU		FACILITY FEE 10 R 800 293 500000 000	780580	11/10/17	0.00	40.00
					CHECK 4270				
BNK2	16		CITY OF COLBY		MOBILE TAX - OCTOBE 10 R 800 213 500000 000	780581	11/10/17	0.00	199.31
					CHECK 15547				
BNK2	17		TAYLOR ELECTRIC - FEDERATED YOUTH FOUNDATION		DONATION 21 R 800 291 500000 943	780582	11/10/17	0.00	250.00
					CHECK 19287				
BNK2	18		GUSTAFSON		SALE OF NON CAP 10 R 800 264 500000 000	780583	11/13/17	0.00	240.00
					CHECK 1993				

BATCH	DESCRIPTION	FISCAL YEAR	POST DATE	BATCH ORIGIN	STATUS
CASH	NOVEMBER 2017 CASH REPORT	2017-2018	11/30/2017	Batch Entry	Batch

BANK	LINE	NAME/PROJ	DESCRIPTION/REFERENCE	ADD'T'L DSC/PAY TYPE	ACCOUNT/QUICK KEY	RECEIPT#	ENTRY DT	DEBIT AMOUNT	CREDIT AMOUNT
. . . CONTINUED									
BNK2	19		STUDENTS	LIFETIME SPORTS	10 R 800 292 143000 000	780585	11/16/17	0.00	270.00
				OTHER TYPE					
BNK2	20		STUDENTS	COURSE FEES	10 R 800 292 136000 000	780585	11/16/17	0.00	90.00
				OTHER TYPE					
BNK2	21		STUDENTS	COURSE FEES	10 R 800 292 121000 000	780585	11/16/17	0.00	50.00
				OTHER TYPE					
BNK2	22		STUDENTS	SWIM SUIT MONEY / M	10 R 800 292 500000 000	780586	11/16/17	0.00	315.00
				OTHER TYPE					
BNK2	23		STUDENTS	ATHLETIC FEES	10 R 800 271 162000 000	780587	11/16/17	0.00	610.00
				OTHER TYPE					
BNK2	24		STUDENTS	SALES OF HELMUT/JER	10 R 800 264 162000 000	780588	11/16/17	0.00	740.00
				OTHER TYPE					
BNK2	25		STUDENTS	PURCHASED JERSEYS	10 R 800 264 162000 000	780589	11/16/17	0.00	60.00
				OTHER TYPE					
BNK2	26		STUDENT	CHROMEBOOK	10 R 800 292 266000 000	780590	11/16/17	0.00	20.00
				CASH					
BNK2	27		STUDENTS	ATHLETIC FEES	10 R 800 292 162000 000	780591	11/16/17	0.00	310.00
				OTHER TYPE					
BNK2	28		COMMUNITY MEMBER	COMMUNITY ED	80 R 800 271 232200 000	780592	11/16/17	0.00	20.00
				OTHER TYPE					
BNK2	29		MIRON	DONATION - GO GREEN	21 R 800 291 500000 942	780593	11/22/17	0.00	500.00
				CHECK 507969					
BNK2	30		STUDENT	ATHLETIC FEES	10 R 800 292 162000 000	780594	11/22/17	0.00	150.00
				OTHER TYPE					
BNK2	31		STUDENTS	PURCHASED JERSEYS	10 R 800 264 162000 000	780595	11/22/17	0.00	120.00
				OTHER TYPE					
BNK2	32		LOOS MACHINE	PRESS BOX	21 R 800 291 500000 943	780596	11/22/17	0.00	1,000.00
				CHECK 27100					
BNK2	33		STUDENTS	ATHLETIC FEES	10 R 800 292 162000 000	780597	11/22/17	0.00	100.00
				OTHER TYPE					
BNK2	34		STUDENTS	ATHLETIC FEES	10 R 800 292 162000 000		11/22/17	0.00	160.00
				OTHER TYPE					
BNK2	35		STUDENTS	ATHLETIC FEES	10 R 800 292 162000 000	780599	11/22/17	0.00	50.00
				CHECK 1310					
BNK2	36		PROVISION	DIVIDEND	10 R 800 971 500000 000	780600	11/22/17	0.00	240.23
				CHECK 24550					

BATCH	DESCRIPTION	FISCAL YEAR	POST DATE	BATCH ORIGIN	STATUS
CASH	NOVEMBER 2017 CASH REPORT	2017-2018	11/30/2017	Batch Entry	Batch

BANK	LINE	NAME/PROJ	DESCRIPTION/REFERENCE	ADD'L DSC/PAY TYPE	ACCOUNT/QUICK KEY	RECEIPT#	ENTRY DT	DEBIT AMOUNT	CREDIT AMOUNT
. . . CONTINUED									
BNK2	37		AFLAC		POLICY LAPSED - RFD 10 R 800 971 500000 000	780601	11/22/17	0.00	15.34
					CHECK 9361224				
BNK2	38		WI DPI		SPED AID 27 R 800 611 150000 000	780602	11/20/17	0.00	55,027.00
					EFT				
BNK2	39		WI DPI		AGR 10 R 800 650 500000 332	780603	11/20/17	0.00	132,557.00
					EFT				
BNK2	40		WI DPI		SCHOOLWIDE CLAIM 10 R 800 730 500000 341	780604	11/27/17	0.00	5,777.92
					EFT				
BNK2	41		WI DPI		FLOW THROUGH 1ST QU 27 R 800 730 150000 341	780605	11/20/17	0.00	25,787.60
					EFT				
BNK2	42		CLARK ELECTRIC		YEARBOOK DONATION 10 R 800 291 500000 000	780606	11/22/17	0.00	40.00
					CHECK 77034				
BNK2	43		STUDENTS		ATHLETIC FEES 10 R 800 292 162000 000	780607	11/30/17	0.00	370.00
					OTHER TYPE				
BNK2	44		OLSON		SHOW CHOIR FLAT FEE 10 R 800 292 500000 000	780608	11/30/17	0.00	175.00
					CHECK 6724				
BNK2	45		OLSON		SHOW CHOIR FEE 10 R 800 292 163314 000	780608	11/30/17	0.00	50.00
					CHECK 6724				
BNK2	46		STUDENT		ATHLETIC FEE 10 R 800 292 162000 000	780609	11/30/17	0.00	10.00
					CASH				
BNK2	47		STUDENT		ATHLETIC FEE 10 R 800 292 162000 000	780610	11/30/17	0.00	10.00
					CASH				
BNK2	48		STUDENT		LOST BOOK 10 R 800 297 500000 000	780611	11/30/17	0.00	7.00
					CASH				
BNK2	49		WEATHERSHIELD		DONATION/BLESSING I 21 R 800 291 500000 941	780612	11/30/17	0.00	500.00
					CASH				
BNK2	50		DONATIONS		BLESSINGS IN A BACK 21 R 800 291 500000 941	780613	11/30/17	0.00	255.00
					CASH				
BNK2	51		STUDENTS		LUNCH MONEY 50 R 800 251 257220 000	780614	11/30/17	0.00	3,950.85
					CASH				
BNK2	52		STUDENTS		MILK MONEY 50 R 800 251 257250 000	780615	11/30/17	0.00	127.50
					OTHER TYPE				
BNK2	53		STUDENTS		LUNCH MONEY/REMOTE 50 R 800 251 257220 000	780616	11/30/17	0.00	15,220.95
					CHECK				
BNK5	54		LUNCH MONEY		50 R 800 251 257220 000	780614	11/30/17	0.00	686.30
					OTHER TYPE				

BATCH	DESCRIPTION	FISCAL YEAR	POST DATE	BATCH ORIGIN	STATUS
CASH	NOVEMBER 2017 CASH REPORT	2017-2018	11/30/2017	Batch Entry	Batch

BANK	LINE	NAME/PROJ	DESCRIPTION/REFERENCE	ADD'L DSC/PAY TYPE	ACCOUNT/QUICK KEY	RECEIPT#	ENTRY DT	DEBIT AMOUNT	CREDIT AMOUNT	
. . . CONTINUED										
BNK5	55		STUDENTS	MILK MONEY	50 R 800 251 257250 000	780615	11/30/17	0.00	34.00	
				OTHER TYPE						
BNK0	56		ADVANTAGE COMMUNITY BANK	INTEREST	10 R 800 280 500000 000	780617	11/30/17	0.00	11.74	
				OTHER TYPE						
BNK5	57		NICOLET NATIONAL BANK	INTEREST	10 R 800 280 500000 000	780618	11/30/17	0.00	62.30	
				OTHER TYPE						
BNK2	58		NICOLET NATIONAL BANK	INTEREST	10 R 800 280 500000 000	780619	11/30/17	0.00	356.47	
				OTHER TYPE						
BNK3	59		NICOLET NATIONAL BANK	INTEREST	39 R 800 280 281000 000	790620	11/30/17	0.00	2.04	
				OTHER TYPE						
BN72	60		NICOLET NATIONAL BANK	INTEREST	72 R 800 280 420000 000	780621	11/30/17	0.00	10.98	
				OTHER TYPE						
BN46	61		NICOLET NATIONAL BANK	INTEREST	46 R 800 280 500000 000	780622	11/30/17	0.00	0.02	
				OTHER TYPE						
BN49	62		NICOLET NATIONAL BANK	INTEREST	49 R 800 280 500000 606	780623	11/30/17	0.00	198.82	
				OTHER TYPE						
BNK2	63		VANCO	ONLINE LUNCH PAYMEN	50 R 800 251 257220 000	790624	11/30/17	0.00	792.00	
				EFT						
BNK2	64		VANCO	ONLINE PAYMENT FEES	50 E 800 940 257220 000	790624	11/30/17	0.88	0.00	
				EFT						
BNK1	65		FORWARD BANK	INTEREST	10 R 800 280 500000 000	790625	11/30/17	0.00	46.77	
				OTHER TYPE						
BNK2	66		MARSHFIELD CLINIC	VERVE CLIMBER DONAT	10 R 800 291 500000 000	780565	11/06/17	0.00	250.00	
				CHECK 116306						
BNK2	67		COMMUNITY MEMBER	SALE OF NONCAP	10 R 800 264 500000 000	780566	11/06/17	0.00	3.00	
				CASH						
BNK2	68		WHITE	SHOW CHOIR BUS FEE	10 R 800 292 163314 000	780567	11/06/17	0.00	50.00	
				CASH						
BNK2	69		ROBIDA	SHOW CHOIR BUS FEE	10 R 800 292 163314 000	780568	11/06/17	0.00	50.00	
				CASH						
								CASH TOTAL	0.00	4,975.85
								CHECK TOTAL	0.00	18,433.36
								EFT TOTAL	3,531.06	254,977.32
								OTHER TYPE TOTAL	0.00	7,576.94
								TOTALS FOR BATCH	3,531.06	285,963.47
								BATCH TOTAL DIFFERENCE	0.00	-282,432.41

69 LINE ENTRIES FOR BATCH NUMBER CASH

DESCRIPTION

DEBIT AMOUNT

CREDIT AMOUNT

CASH GRAND TOTAL	0.00	4,975.85
CHECK GRAND TOTAL	0.00	18,433.36
EFT GRAND TOTAL	3,531.06	254,977.32
OTHER TYPE GRAND TOTAL	0.00	7,576.94

69 LINE ENTRIES FOR 1 BATCH	GRAND TOTALS	3,531.06	285,963.47
	GRAND TOTAL DIFFERENCE	0.00	-282,432.41

***** End of report *****

BATCH	DESCRIPTION	FISCAL YEAR	POST DATE	BATCH ORIGIN	STATUS
ADM	CASH REPORT FOR ADM ACCT	2017-2018	10/31/2017	Batch Entry	Batch

BANK	LINE	NAME/PROJ	DESCRIPTION/REFERENCE	ADD'L DSC/PAY TYPE	ACCOUNT/QUICK KEY	RECEIPT#	ENTRY DT	DEBIT AMOUNT	CREDIT AMOUNT
B149	1		ADM		INTEREST/10/31/2017 49 R 800 280 500000 606	780584	10/31/17	0.00	3,179.21
					OTHER TYPE				
					OTHER TYPE GRAND TOTAL			0.00	3,179.21
					1 LINE ENTRY FOR 1 BATCH			0.00	3,179.21
					GRAND TOTAL DIFFERENCE			0.00	-3,179.21

***** End of report *****

Check Nbr	Vendor Name	Check Date	Invoice Number	Invoice Desc	PO Number	Invoice Amount	Check Amount
74562	CESA #2	11/21/2017	17	WISCONSIN SCHOOLS DIGITAL LIBRARY CONSORTIUM	2001718054	1,323.00	1,323.00
10 E 200 431 222200 000				GENERAL FUND/LMC - INST SERVICE/AUDIO-VISUAL MEDIA		1,323.00	
74563	CHARTER COMMUNICATIONS	11/21/2017	0022996111117	ACCOUNT #8245117950022996	0	114.24	114.24
10 E 800 358 266000 000				GENERAL FUND/TECHNOLOGY COORD/PROJECTS/ON-LINE COMMUNIC		114.24	
74564	POSTMASTER	11/21/2017	ANNUAL FEE	MAILING PERMIT	0	225.00	225.00
10 E 800 353 263300 000				GENERAL FUND/PUBLIC INFORMATION/POSTAGE		225.00	
74565	Vendor Continued Void	11/21/2017					0.00
74566	Vendor Continued Void	11/21/2017					0.00
74567	COUNTY MARKET ACCOUNT #6017	11/21/2017	001010441747	BLESSINGS IN A BACKPACK	0	163.10	640.36
21 E 800 415 110000 941				SPECIAL PROJECTS/ELEMENTARY CURRICULUM/FOOD		163.10	
			001025721357	rewards	6021718028	13.28	
27 E 400 415 158100 341				SPECIAL EDUC./MULTICATEGORICAL HANDICAPPED/FOOD		13.28	
			001051061317	purchase grocery/kitchen items to be used in Life Skills/Math/Readin g classes to meet student IEP objectives	6021718034	62.45	
27 E 400 415 158100 341				SPECIAL EDUC./MULTICATEGORICAL HANDICAPPED/FOOD		62.45	
			001083750938	purchase grocery/kitchen items to be used in Life Skills/Math/Readin g classes to meet student IEP objectives	6021718034	85.69	
27 E 400 415 158100 341				SPECIAL EDUC./MULTICATEGORICAL HANDICAPPED/FOOD		85.69	
			001088371456	purchase grocery/kitchen items to be used in Life Skills/Math/Readin g classes to meet student IEP objectives	6021718034	24.85	
27 E 400 415 158100 341				SPECIAL EDUC./MULTICATEGORICAL HANDICAPPED/FOOD		24.85	

Check Nbr	Vendor Name	Check Date	Invoice Number	Invoice Desc	PO Number	Invoice Amount	Check Amount
			002000891328	Open PO to purchase grocery kitchen items to use during life skills/math/Readin g class to meet student IEP objectives	6021718045	39.93	
27 E 200 415 158100 341				SPECIAL EDUC./MULTICATEGORICAL HANDICAPPED/FOOD		39.93	
			0020014514505	rewards	6021718028	32.29	
27 E 400 415 158100 341				SPECIAL EDUC./MULTICATEGORICAL HANDICAPPED/FOOD		32.29	
			003000721403	rewards	6021718028	29.18	
27 E 400 415 158100 341				SPECIAL EDUC./MULTICATEGORICAL HANDICAPPED/FOOD		29.18	
			003000851411	Food for Life Skills and Math Classes	6021718057	22.65	
27 E 400 415 158100 341				SPECIAL EDUC./MULTICATEGORICAL HANDICAPPED/FOOD		22.65	
			007001321015	FUNERAL FLOWERS	0	80.99	
10 E 800 411 231100 000				GENERAL FUND/BOARD OF EDUCATION/GENERAL SUPPLIES		80.99	
			007002051252	Open PO to purchase grocery kitchen items to use during life skills/math/Readin g class to meet student IEP objectives	6021718045	15.96	
27 E 200 415 158100 341				SPECIAL EDUC./MULTICATEGORICAL HANDICAPPED/FOOD		15.96	
			007002701409	FUNERAL FLOWERS	0	69.99	
10 E 800 411 231100 000				GENERAL FUND/BOARD OF EDUCATION/GENERAL SUPPLIES		69.99	
74568	COUNTY MARKET - F&CE ACCT 8007	11/21/2017	OCTOBER 2017	Open purchase order for groceries for FACE classes	4011718009	619.89	619.89
10 E 400 415 135000 000				GENERAL FUND/FAMILY & CONSUMER EC/FOOD		619.89	
74569	DEPT SAFETY & PROFESSIONAL SER	11/21/2017	454452	PERMIT TO OPERATE	0	50.00	50.00
10 E 800 940 253300 000				GENERAL FUND/OPERATION OF BUILDINGS/DUES & FEES		50.00	
74570	JIM T GILBERTSON	11/21/2017	OFFICIAL	GIRLS VARSITY BASKETBALL 11-21-17	0	90.00	90.00
10 E 400 310 162105 000				GENERAL FUND/GIRLS BASKETBALL/PERSONAL SERVICES		90.00	

Check Nbr	Vendor Name	Check Date	Invoice Number	Invoice Desc	PO Number	Invoice Amount	Check Amount
74571	PAUL KNETTER	11/21/2017	OFFICIAL	GIRLS JV BASKETBALL 11-21-17	0	47.00	47.00
10 E 400 310 162105 000			GENERAL FUND/GIRLS BASKETBALL/PERSONAL SERVICES			47.00	
74572	JAYME OR KIM MARTEN	11/21/2017	08/21/17-10/31/17	ACA MILEAGE - 702 MILES	0	224.64	224.64
10 E 800 341 256730 000			GENERAL FUND/PARENT TRANSPORTATION/PUPIL TRAVEL			224.64	
74573	NASSCO INC	11/21/2017	S2248905.001	ELECTORSTATIC SPRAYER	0	4,457.83	6,260.53
10 E 800 440 253300 000			GENERAL FUND/OPERATION OF BUILDINGS/NON-CAPITAL EQUIPME			4,457.83	
			S2254097.001	LAUNDRY DETERGENT, BOWL CLEANER, URINAL SCREEN, EASY TRAP DUSTER, BATH TISSUE, HAND SOAP	0	1,727.80	
10 E 800 411 253300 000			GENERAL FUND/OPERATION OF BUILDINGS/GENERAL SUPPLIES			1,727.80	
			S2256435.001	VINYL GLOVE, MAGIC ERASER	0	74.90	
10 E 800 411 253300 000			GENERAL FUND/OPERATION OF BUILDINGS/GENERAL SUPPLIES			74.90	
74574	NELCO	11/21/2017	5738792 RI	#9 SINGLE WINDOW ENV/IMP	0	433.20	433.20
10 E 800 411 232100 000			GENERAL FUND/OFFICE OF SUPERINTENDENT/GENERAL SUPPLIES			433.20	
74575	JON PAYNE	11/21/2017	OFFICIAL	GIRLS VARSITY BASKETBALL 11-21-17	0	90.00	90.00
10 E 400 310 162105 000			GENERAL FUND/GIRLS BASKETBALL/PERSONAL SERVICES			90.00	
74576	TREY RAU	11/21/2017	OFFICIAL	GIRLS JV BASKETBALL 11-21-17	0	47.00	47.00
10 E 400 310 162105 000			GENERAL FUND/GIRLS BASKETBALL/PERSONAL SERVICES			47.00	
74577	Vendor Continued Void	11/21/2017					0.00
74578	Vendor Continued Void	11/21/2017					0.00
74579	Vendor Continued Void	11/21/2017					0.00
74580	RCU CARDHOLDER SERVICES	11/21/2017	24005947284100294647	WIAA STATE FOOTBALL TICKETS	0	73.00	3,318.07
10 E 800 940 221300 916			GENERAL FUND/INST. STAFF SERV. - TRAINING/DUES & FEES			73.00	
			24108477290900017239	WILDERNESS RESORT - PENRY	0	124.49	
27 E 800 342 223300 341			SPECIAL EDUC./EEN DIRECTOR/EMPLOYEE TRAVEL & EXP.			124.49	

Check Nbr	Vendor Name	Check Date	Invoice Number	Invoice Desc	PO Number	Invoice Amount	Check Amount
			24110397280816645305	HOLIDAY INN - SZEMBORSKI- WEBIT	0	119.00	
10 E 800 342 221300 401				GENERAL FUND/INST. STAFF SERV. - TRAINING/EMPLOYEE TRAV		119.00	
			24183107271900012301	EDHELPER EVERYTHING ONLINE SUBSCRIPTION	1021718039	55.98	
10 E 100 435 110000 332				GENERAL FUND/ELEMENTARY CURRICULUM/PROGRAMMED COMPUTER		55.98	
			24323007283207049600	RIFTON HTS DEFLECTORS	0	94.95	
27 E 800 411 218200 341				SPECIAL EDUC./PHYSICAL THERAPY/GENERAL SUPPLIES		94.95	
			24325457274900018101	2017-2018 - MS - 411 - DEMCO	2001718012	178.74	
10 E 200 411 222200 000				GENERAL FUND/LMC - INST SERVICE/GENERAL SUPPLIES		178.74	
			2432545727890001591	KALAHARI RESORT - MCLELLAN- SLATE	0	119.00	
10 E 800 342 221300 000				GENERAL FUND/INST. STAFF SERV. - TRAINING/EMPLOYEE TRAV		119.00	
			24325457278900015915	KALAHARI RESORT - GRAUN - SLATE	0	119.00	
10 E 800 342 221300 000				GENERAL FUND/INST. STAFF SERV. - TRAINING/EMPLOYEE TRAV		119.00	
			2432545729690017834	KALAHARI - SLATE MCLELLAN	0	119.00	
10 E 800 342 221300 000				GENERAL FUND/INST. STAFF SERV. - TRAINING/EMPLOYEE TRAV		119.00	
			24325457296900178347	KALAHARI - SLATE GRAUN	0	119.00	
10 E 800 342 221300 000				GENERAL FUND/INST. STAFF SERV. - TRAINING/EMPLOYEE TRAV		119.00	
			24492157296894537161	2017-2018 WSCA MEMBERSHIP - SCHMIDT	0	70.00	
10 E 100 940 221300 000				GENERAL FUND/INST. STAFF SERV. - TRAINING/DUES & FEES		70.00	
			24692167272100248133	STUDENT -CENTERED COACHING BOOKS	0	187.83	
10 E 800 411 221300 000				GENERAL FUND/INST. STAFF SERV. - TRAINING/GENERAL SUPPL		187.83	
			24692167277100743090	3 COLOR MUSLIN BACKDROP	0	64.99	
10 E 400 411 136000 000				GENERAL FUND/TECH ED/GENERAL SUPPLIES		64.99	
			24692167277100795866	Zalman ZM-Mic1	3001718011	109.80	
10 E 200 411 122000 141				GENERAL FUND/ENGLISH/GENERAL SUPPLIES		109.80	
			24692167279100879430	MATH QUICK LOOK	0	41.80	

Check Nbr	Vendor Name	Check Date	Invoice Number	Invoice Desc	PO Number	Invoice Amount	Check Amount
				CARDS DOT PATTERNS K-1			
10 E 100 411 110000 000				GENERAL FUND/ELEMENTARY CURRICULUM/GENERAL SUPPLIES		41.80	
			24692167283100424599	5" round mirror for woods I project	4011718137	69.99	
10 E 400 411 136000 000				GENERAL FUND/TECH ED/GENERAL SUPPLIES		69.99	
			24692167283100490382	BOOK	0	15.98	
27 E 100 411 158100 341				SPECIAL EDUC./MULTICATEGORICAL HANDICAPPED/GENERAL SUPP		15.98	
			24692167284100857926	FIDGET TOY	0	14.80	
27 E 100 411 158100 341				SPECIAL EDUC./MULTICATEGORICAL HANDICAPPED/GENERAL SUPP		14.80	
			24692167285100232422	BOOKS , BATTERIES	0	59.05	
27 E 100 411 158100 341				SPECIAL EDUC./MULTICATEGORICAL HANDICAPPED/GENERAL SUPP		59.05	
			24692167285100678314	BOOK	0	5.29	
27 E 100 411 158100 341				SPECIAL EDUC./MULTICATEGORICAL HANDICAPPED/GENERAL SUPP		5.29	
			24692167289100945946	SLATE CONFERENCE - GRAUN, MCCLELLAN, MCCONNELL	0	747.00	
10 E 800 310 221300 000				GENERAL FUND/INST. STAFF SERV. - TRAINING/PERSONAL SERV		747.00	
			24692167299200634361	G5769 - 48" PAN & BOX BRAKE - 16GAUGE	0	768.00	
10 E 400 411 136000 000				GENERAL FUND/TECH ED/GENERAL SUPPLIES		768.00	
			2471705728416284731	DOJ BACKGROUND CHECK	0	7.00	
10 E 800 310 232100 000				GENERAL FUND/OFFICE OF SUPERINTENDENT/PERSONAL SERVICES		7.00	
			24717057284162847315	DOJ BACKGROUND CHECK	0	7.00	
10 E 800 310 232100 000				GENERAL FUND/OFFICE OF SUPERINTENDENT/PERSONAL SERVICES		7.00	
			24717057286172862903	DOJ BACKGROUND CHECK	0	7.00	
10 E 800 310 232100 000				GENERAL FUND/OFFICE OF SUPERINTENDENT/PERSONAL SERVICES		7.00	
			24717057287128790937	DOJ BACKGROUND CHECK	0	7.00	
10 E 800 310 232100 000				GENERAL FUND/OFFICE OF SUPERINTENDENT/PERSONAL SERVICES		7.00	
			24717057292162926674	DOJ BACKGROUND CHECK	0	7.00	

Check Nbr	Vendor Name	Check Date	Invoice Number	Invoice Desc	PO Number	Invoice Amount	Check Amount
10 E 800 310 232100 000				GENERAL FUND/OFFICE OF SUPERINTENDENT/PERSONAL SERVICES		7.00	
			24717057292162926675	DOJ BACKGROUND CHECK	0	7.00	
10 E 800 310 232100 000				GENERAL FUND/OFFICE OF SUPERINTENDENT/PERSONAL SERVICES		7.00	
			24717057297162975311	DOJ BACKGROUND CHECK	0	7.00	
10 E 800 310 232100 000				GENERAL FUND/OFFICE OF SUPERINTENDENT/PERSONAL SERVICES		7.00	
			24717057301230040883	2017 BUILDING HEART OF SCHOOLS CONFERENCE - M.TESMER, WRIGHT, WOZNIAK	0	375.00	
10 E 200 310 213000 000				GENERAL FUND/PUPIL SERVICES - GUIDANCE/PERSONAL SERVICE		125.00	
10 E 200 310 221300 000				GENERAL FUND/INST. STAFF SERV. - TRAINING/PERSONAL SERV		125.00	
27 E 800 310 221300 341				SPECIAL EDUC./INST. STAFF SERV. - TRAINING/PERSONAL SER		125.00	
			24755427292172924564	HILTON - LARSEN	0	359.26	
10 E 200 342 221300 000				GENERAL FUND/INST. STAFF SERV. - TRAINING/EMPLOYEE TRAV		179.63	
10 E 400 342 221300 000				GENERAL FUND/INST. STAFF SERV. - TRAINING/EMPLOYEE TRAV		179.63	
			24765017272286824301	EDIHELPER - WOLF	0	35.98	
27 E 400 940 158100 341				SPECIAL EDUC./MULTICATEGORICAL HANDICAPPED/DUES & FEES		35.98	
			24906417298046017966	SURVEYMONKEY	0	250.00	
10 E 800 411 231100 000				GENERAL FUND/BOARD OF EDUCATION/GENERAL SUPPLIES		250.00	
			74431057298200370999	CREDIT VOUCHER - SWIMOUTLET MS SWIM	0	-864.00	
10 E 200 420 162124 000				GENERAL FUND/GIRLS SWIMMING/APPAREL		-864.00	
			7475542727216269002	CREDIT MEMO - MADISON CONCOURSE	0	-47.85	
10 E 800 342 232100 000				GENERAL FUND/OFFICE OF SUPERINTENDENT/EMPLOYEE TRAVEL &		-47.85	
			74755427272162690022	CREDIT MEMO - MADISON CONCOURSE	0	-116.01	
10 E 800 342 232100 000				GENERAL FUND/OFFICE OF SUPERINTENDENT/EMPLOYEE TRAVEL &		-116.01	
74581 MARK SKIBBA		11/21/2017	OFFICIAL	GIRLS VARSITY BASKETBALL 11-21-17	0	90.00	90.00
10 E 400 310 162105 000				GENERAL FUND/GIRLS BASKETBALL/PERSONAL SERVICES		90.00	
74582 TEAM SPORTING GOODS INC		11/21/2017	AAD004742	Boys basketball 2017-2018	8010171825	392.00	1,545.65
10 E 400 420 162205 000				GENERAL FUND/BOYS BASKETBALL/APPAREL		392.00	

Check Nbr	Vendor Name	Check Date	Invoice Number	Invoice Desc	PO Number	Invoice Amount	Check Amount
			AAD004743	Boys basketball 2017-2018	8010171825	392.00	
10 E 400 420 162205 000				GENERAL FUND/BOYS BASKETBALL/APPAREL		392.00	
			AAF007980	Medical, football and letter supplies	8010171802	761.65	
10 E 800 411 162001 000				GENERAL FUND/ATHLETICS-GENERAL/GENERAL SUPPLIES		725.19	
10 E 400 411 162210 000				GENERAL FUND/FOOTBALL/GENERAL SUPPLIES		36.46	
74583 TRUGREEN PROCESSING CENTER		11/21/2017	76326993	VARSITY FB FIELD LAWN SERVICE	0	386.25	386.25
10 E 800 320 254200 000				GENERAL FUND/MAINTENANCE-SITES/PROPERTY SERVICE		386.25	
74584 USI INC (PAYMENTS)		11/21/2017	W013014500011	2017-2018 - HS/MS - 411 - USI	2001718013	150.43	150.43
10 E 200 411 222200 000				GENERAL FUND/LMC - INST SERVICE/GENERAL SUPPLIES		75.22	
10 E 400 411 222200 000				GENERAL FUND/LMC - INST SERVICE/GENERAL SUPPLIES		75.21	
74585 MARK WEBER		11/21/2017	REIMBURSEMENT	BOYS BASKETBALL SPORTS FEE	0	50.00	50.00
10 R 800 292 162000 000				GENERAL FUND/ATHLETIC AND SPORT/STUDENT FEES		50.00	
74586 WE ENERGIES		11/21/2017	ADAMS HOUSE	10/13/17-11/10/17	0	61.55	5,373.14
10 E 800 331 253300 000				GENERAL FUND/OPERATION OF BUILDINGS/GAS FOR HEAT		61.55	
				ELEMENTARY SCHOOL 10/12/17-11/10/17	0	964.27	
10 E 800 331 253300 000				GENERAL FUND/OPERATION OF BUILDINGS/GAS FOR HEAT		964.27	
				HIGH SCHOOL BACK 10/13/17-11/13/17	0	3,063.45	
10 E 800 331 253300 000				GENERAL FUND/OPERATION OF BUILDINGS/GAS FOR HEAT		3,063.45	
				HIGH SCHOOL FRONT 10/12/17-11/10/17	0	1,272.21	
10 E 800 331 253300 000				GENERAL FUND/OPERATION OF BUILDINGS/GAS FOR HEAT		1,272.21	
				MIDDLE SCHOOL 10/12/17-11/10/17	0	11.66	
10 E 800 331 253300 000				GENERAL FUND/OPERATION OF BUILDINGS/GAS FOR HEAT		11.66	
74587 WIL-KIL PEST CONTROL CORP		11/21/2017	327114	MONTHLY SERVICE- HS	0	39.50	77.50
10 E 800 320 253300 000				GENERAL FUND/OPERATION OF BUILDINGS/PROPERTY SERVICE		39.50	
			3272626	MONTHLY SERVICE- MS	0	38.00	
10 E 800 320 253300 000				GENERAL FUND/OPERATION OF BUILDINGS/PROPERTY SERVICE		38.00	
74588 WISCONSIN TAXPAYERS ALLIANCE		11/21/2017	SCHOOLFACTS	SCHOOLFACTS2017 AND DISTRICT HISTORY REPORT	0	51.65	51.65
10 E 800 411 232100 000				GENERAL FUND/OFFICE OF SUPERINTENDENT/GENERAL SUPPLIES		51.65	

Check Nbr Vendor Name	Check Date Invoice Number	Invoice Desc	PO Number	Invoice Amount	Check Amount
74589 WSRA	11/21/2017 11484	WSRA MEMBERSHIP	1021718052	37.00	37.00
10 E 100 310 221300 332		GENERAL FUND/INST. STAFF SERV. - TRAINING/PERSONAL SERV		37.00	
74590 SAM ZIER	11/21/2017 OFFICIAL	BOYS MS	0	55.00	55.00
		BASKETBALL			
		11-21-17			
10 E 200 310 162205 000		GENERAL FUND/BOYS BASKETBALL/PERSONAL SERVICES		55.00	
		29 Computer	Check(s) For a Total of		21,299.55

Check Nbr	Vendor Name	Check Date	Invoice Number	Invoice Desc	PO Number	Invoice Amount	Check Amount
74591	ALTOONA SHOW CHOIR/ALTOONA H.S	11/27/2017	FEE	Show Choir Festival for the Varsity Show Choir Registration	4011718173	250.00	250.00
10 E 400 940 125400 000				GENERAL FUND/VOCAL MUSIC/DUES & FEES		250.00	
74592	ALLEN ASHBECK	11/27/2017	OFFICIAL	GIRLS VARISTY BASKETBALL 11-30-2017	0	90.00	90.00
10 E 400 310 162105 000				GENERAL FUND/GIRLS BASKETBALL/PERSONAL SERVICES		90.00	
74593	B*JAZZEDLED	11/27/2017	FEE	HS Show Choir Festival Registration Burlington Wisconsin.	4011718171	600.00	600.00
10 E 400 940 125400 000				GENERAL FUND/VOCAL MUSIC/DUES & FEES		600.00	
74594	BENTON COMMUNITY HIGH SCHOOL	11/27/2017	FEE	Show Choir Festival Registration Benton Community High School Attn: John Hayden P.O. Box 70 Van Horne, IA 52346	4011718172	300.00	300.00
10 E 400 940 125400 000				GENERAL FUND/VOCAL MUSIC/DUES & FEES		300.00	
74595	BRIER BERGERSON	11/27/2017	OFFICIAL	GIRLS VARISTY BASKETBALL 11-30-2017	0	90.00	90.00
10 E 400 310 162105 000				GENERAL FUND/GIRLS BASKETBALL/PERSONAL SERVICES		90.00	
74596	MARK DECKER	11/27/2017	OFFICIAL	BOYS VARSITY BASKETBALL 11-28-2017	0	90.00	90.00
10 E 400 310 162205 000				GENERAL FUND/BOYS BASKETBALL/PERSONAL SERVICES		90.00	
74597	DELTA DENTAL OF WISCONSIN	11/27/2017	1099042	DECEMBER 2017 DENTAL INSURANCE	0	10,414.85	10,338.19
10 L 000 000 811632 000				GENERAL FUND/DENTAL INS.		10,414.85	
			1099043	DECEMBER 2017 DENTAL INSURANCE/COBRA ADJUSTMENT	0	-76.66	
10 L 000 000 811632 000				GENERAL FUND/DENTAL INS.		-76.66	
74598	LUCAS HEIDMANN	11/27/2017	OFFICIAL	BOYS VARSITY	0	90.00	90.00

Check Nbr	Vendor Name	Check Date	Invoice Number	Invoice Desc	PO Number	Invoice Amount	Check Amount
				BASKETBALL 11-28-2017			
10 E 400 310 162205 000				GENERAL FUND/BOYS BASKETBALL/PERSONAL SERVICES		90.00	
74599	NATHANIEL HILLIARD	11/27/2017	OFFICIAL	BOYS VARSITY BASKETBALL 11-28-2017	0	90.00	90.00
10 E 400 310 162205 000				GENERAL FUND/BOYS BASKETBALL/PERSONAL SERVICES		90.00	
74600	PAUL KNETTER	11/27/2017	OFFICIAL	BOYS JV BASKETBALL 11-28-2017	0	47.00	47.00
10 E 400 310 162205 000				GENERAL FUND/BOYS BASKETBALL/PERSONAL SERVICES		47.00	
74601	TREY RAU	11/27/2017	OFFICIAL	BOYS JV BASKETBALL 11-28-2017	0	47.00	47.00
10 E 400 310 162205 000				GENERAL FUND/BOYS BASKETBALL/PERSONAL SERVICES		47.00	
74602	GRAEME WILLIAMS	11/27/2017	OFFICIAL	GIRLS VARISTY BASKETBALL 11-30-2017	0	90.00	90.00
10 E 400 310 162105 000				GENERAL FUND/GIRLS BASKETBALL/PERSONAL SERVICES		90.00	

12 Computer Check(s) For a Total of 12,122.19

Check Nbr	Vendor Name	Check Date	Invoice Number	Invoice Desc	PO Number	Invoice Amount	Check Amount
74604	AMERICAN WELDING & GAS INC	12/04/2017	05191734	CARBON DIOXIDE - POOL	0	156.41	156.41
10 E 800 411 253300 000				GENERAL FUND/OPERATION OF BUILDINGS/GENERAL SUPPLIES		156.41	
74605	DAVID BARCLAY	12/04/2017	OFFICIAL	GIRLS VARSITY BASKETBALL 12-08-2017	0	90.00	90.00
10 E 400 310 162105 000				GENERAL FUND/GIRLS BASKETBALL/PERSONAL SERVICES		90.00	
74606	LAWRENCE K BUCHBERGER	12/04/2017	OFFICIAL	BOYS VARSITY BASKETBALL 12-07-2017	0	90.00	90.00
10 E 400 310 162205 000				GENERAL FUND/BOYS BASKETBALL/PERSONAL SERVICES		90.00	
74607	CHARTER COMMUNICATIONS	12/04/2017	0003269112317	ACCOUNT #8245 11 795 0003269	0	551.63	551.63
10 E 800 358 266000 000				GENERAL FUND/TECHNOLOGY COORD/PROJECTS/ON-LINE COMMUNIC		551.63	
74608	CHESTNUT CONSULTING	12/04/2017	MSP-2923	TECHNOLOGY SERVICE AGREEMENT	0	8,250.00	8,250.00
10 E 800 310 266000 000				GENERAL FUND/TECHNOLOGY COORD/PROJECTS/PERSONAL SERVICE		8,250.00	
74609	COMPLETE CONTROL, INC.	12/04/2017	SRVCE033842	TESTED 4 BACKFLOW DEVICES AND REGISTERED W/ STATE OF WI	0	560.50	1,346.09
10 E 800 320 253300 000				GENERAL FUND/OPERATION OF BUILDINGS/PROPERTY SERVICE		560.50	
			SRVCE033843	REPLACED INDUCER MOTOR AND WHEEL ON REZNOR MAKE-UP AIR UNIT FOR POOL	0	785.59	
10 E 800 320 253300 000				GENERAL FUND/OPERATION OF BUILDINGS/PROPERTY SERVICE		785.59	
74610	CONSULTING WITH CLARITY	12/04/2017	1709	SERVICE CALL 11-20-17	0	60.00	60.00
10 E 800 320 253300 000				GENERAL FUND/OPERATION OF BUILDINGS/PROPERTY SERVICE		60.00	
74611	MARK D DERFUS	12/04/2017	OFFICIAL	BOYS VARSITY BASKETBALL 12-05-2017	0	90.00	90.00
10 E 400 310 162205 000				GENERAL FUND/BOYS BASKETBALL/PERSONAL SERVICES		90.00	
74612	DON JOHNSTON	12/04/2017	00440308	WRITER AND SNAP AND READ ONE YEAR	1011718018	1,743.12	1,743.12
10 E 800 435 120000 000				GENERAL FUND/REGULAR CURRICULUM/PROGRAMMED COMPUTER SOF		1,743.12	
74613	ERIC DRANGSTVEIT	12/04/2017	OFFICIAL	GIRLS VARSITY BASKETBALL 12-08-2017	0	90.00	90.00

Check Nbr	Vendor Name	Check Date	Invoice Number	Invoice Desc	PO Number	Invoice Amount	Check Amount
10 E 400 310 162105 000				GENERAL FUND/GIRLS BASKETBALL/PERSONAL SERVICES		90.00	
74614	MICHAEL ENDREAS	12/04/2017	OFFICIAL	BOYS VARSITY BASKETBALL 12-05-2017	0	90.00	90.00
10 E 400 310 162205 000				GENERAL FUND/BOYS BASKETBALL/PERSONAL SERVICES		90.00	
74615	JANE FRICKE THIEME	12/04/2017	NOVEMBER 2017	RIDE BUS W/STUDENTS 105 MILES	0	56.18	56.18
27 E 800 342 159100 341				SPECIAL EDUC./EEN AIDES/EMPLOYEE TRAVEL & EXP.		56.18	
74616	KAYTRINA FRIEDLI	12/04/2017	11-28-17	Student community outings to fulfill IEP objectives in the following areas : Lifeskills, Reading Fluency through daily activities, Math objectives (money Skills), Social Skills Objectives and Behavior Objectives \$7.00 per student X 11 students= \$77.00 per month X 9 months = \$693.00	6021718049	75.38	75.38
27 E 200 411 158100 341				SPECIAL EDUC./MULTICATEGORICAL HANDICAPPED/GENERAL SUPP		75.38	
74617	FRONTIER	12/04/2017	11/16/17-12/15/17	ACCOUNT# 715-223-4539-01129 0-5	0	50.70	50.70
10 E 800 355 263300 000				GENERAL FUND/PUBLIC INFORMATION/TELEPHONE		50.70	
74618	DIANE HANSON	12/04/2017	NOVEMBER 2017	RIDE BUS W/STUDENTS 75 MILES	0	40.13	40.13
27 E 800 342 159100 341				SPECIAL EDUC./EEN AIDES/EMPLOYEE TRAVEL & EXP.		40.13	
74619	SUSAN HUBING	12/04/2017	NOVEMBER 2017	RIDE BUS W/STUDENTS 120 MILES	0	64.20	64.20
27 E 800 342 159100 341				SPECIAL EDUC./EEN AIDES/EMPLOYEE TRAVEL & EXP.		64.20	
74620	GARY O. IVERSON	12/04/2017	OFFICIAL	GIRLS VARSITY BASKETBALL 12-08-2017	0	90.00	90.00

Check Nbr	Vendor Name	Check Date	Invoice Number	Invoice Desc	PO Number	Invoice Amount	Check Amount
10 E 400 310 162105 000				GENERAL FUND/GIRLS BASKETBALL/PERSONAL SERVICES		90.00	
74621	MICHAEL TODD KLEIN	12/04/2017	OFFICIAL	BOYS VARSITY BASKETBALL 12-05-2017	0	90.00	90.00
10 E 400 310 162205 000				GENERAL FUND/BOYS BASKETBALL/PERSONAL SERVICES		90.00	
74622	PAUL KNETTER	12/04/2017	OFFICIAL	GIRLS JV BASKETBALL 12-08-2017	0	47.00	47.00
10 E 400 310 162105 000				GENERAL FUND/GIRLS BASKETBALL/PERSONAL SERVICES		47.00	
74623	PAUL KNETTER	12/04/2017	OFFICIAL	BOYS C-TEAM BASKETBALL 12-07-2017	0	40.00	74.50
10 E 400 310 162205 000				GENERAL FUND/BOYS BASKETBALL/PERSONAL SERVICES		40.00	
			OFFICIAL	BOYS MS BASKETBALL 12-07-2017	0	34.50	
10 E 200 310 162205 000				GENERAL FUND/BOYS BASKETBALL/PERSONAL SERVICES		34.50	
74624	ANDREW M KRAUTKRAMER	12/04/2017	OFFICIAL	BOYS VARSITY BASKETBALL 12-07-2017	0	90.00	90.00
10 E 400 310 162205 000				GENERAL FUND/BOYS BASKETBALL/PERSONAL SERVICES		90.00	
74625	LIBRARIAN'S CHOICE	12/04/2017	1303350	2017-2018 - HS - 432 - Various Vendors	2001718067	316.84	835.19
10 E 400 432 222200 000				GENERAL FUND/LMC - INST SERVICE/LIBRARY BOOKS		316.84	
			1303350	2017-2018 - MS - 432 - Various Vendors	2001718058	518.35	
10 E 200 432 222200 000				GENERAL FUND/LMC - INST SERVICE/LIBRARY BOOKS		518.35	
74626	MARSHFIELD BOOK & STATIONARY	12/04/2017	346333	SUPPLIES	1011718015	2,749.58	2,749.58
10 E 800 411 120000 000				GENERAL FUND/REGULAR CURRICULUM/GENERAL SUPPLIES		2,749.58	
74627	MCGRAW HILL HOLDINGS LLC	12/04/2017	100436376001	math workbooks reading workbooks textbooks	6021718086	306.33	306.33
27 E 200 470 158100 341				SPECIAL EDUC./MULTICATEGORICAL HANDICAPPED/TEXTBKS/WORK		306.33	
74628	NASSCO INC	12/04/2017	S2251419.001	RINSE DRY ADDITIVE, SOLID POWER XL, SCOURING SPONGE MEDIUM	0	290.82	722.27

Check Nbr	Vendor Name	Check Date	Invoice Number	Invoice Desc	PO Number	Invoice Amount	Check Amount
50 E 800 419 257220 000				FOOD SERVICE FUND/FOOD SERVICE-LUNCH PROGRAM/OTHER SUPP		290.82	
			S2252623.001	MEGACATRIDGE NAPKINS	0	198.45	
50 E 800 419 257220 000				FOOD SERVICE FUND/FOOD SERVICE-LUNCH PROGRAM/OTHER SUPP		198.45	
			S2254220.001	KNIFE AND GEAR SET FOR MODEL 266	0	233.00	
50 E 800 419 257220 000				FOOD SERVICE FUND/FOOD SERVICE-LUNCH PROGRAM/OTHER SUPP		233.00	
74629	TIM PETERSON	12/04/2017	00105	AERIAL PHOTO - ELEMENTARY	0	50.00	50.00
10 E 800 310 232100 000				GENERAL FUND/OFFICE OF SUPERINTENDENT/PERSONAL SERVICES		50.00	
74630	PIONEER MANUFACTURING COMPANY	12/04/2017	INV654593	BRITE STRIPE WHITE 5GL	0	475.00	475.00
10 E 800 411 254200 000				GENERAL FUND/MAINTENANCE-SITES/GENERAL SUPPLIES		475.00	
74631	RANDY RASMUSSEN	12/04/2017	OFFICIAL	BOYS VARSITY BASKETBALL 12-07-2017	0	90.00	90.00
10 E 400 310 162205 000				GENERAL FUND/BOYS BASKETBALL/PERSONAL SERVICES		90.00	
74632	TREY RAU	12/04/2017	OFFICIAL	GIRLS JV BASKETBALL 12-08-2017	0	47.00	47.00
10 E 400 310 162105 000				GENERAL FUND/GIRLS BASKETBALL/PERSONAL SERVICES		47.00	
74633	TREY RAU	12/04/2017	OFFICIAL	BOYS C-TEAM BASKETBALL 12-07-2017	0	40.00	74.50
10 E 400 310 162205 000				GENERAL FUND/BOYS BASKETBALL/PERSONAL SERVICES		40.00	
			OFFICIAL	BOYS MS BASKETBALL 12-07-2017	0	34.50	
10 E 200 310 162205 000				GENERAL FUND/BOYS BASKETBALL/PERSONAL SERVICES		34.50	
74634	RUDER WARE, L.L.S.C.	12/04/2017	233586	CONTINUE WORK ON PENSION PLAN W/ KEENE & BROOKS	0	2,479.00	2,479.00
10 E 800 310 231500 000				GENERAL FUND/BOARD OF ED. LEGAL/PERSONAL SERVICES		2,479.00	
74635	SHELL	12/04/2017	79387155711	ACCT: 079 387 155	0	240.01	251.09
10 E 800 348 221300 000				GENERAL FUND/INST. STAFF SERV. - TRAINING/VEHICLE FUEL		41.54	
10 E 800 348 161311 000				GENERAL FUND/FUTURE FARMERS OF AMERICA/VEHICLE FUEL		114.97	
27 E 400 348 158100 341				SPECIAL EDUC./MULTICATEGORICAL HANDICAPPED/VEHICLE FUEL		35.23	
10 E 400 348 162210 000				GENERAL FUND/FOOTBALL/VEHICLE FUEL		20.86	
27 E 901 348 158100 341				SPECIAL EDUC./MULTICATEGORICAL HANDICAPPED/VEHICLE FUEL		27.41	

Check Nbr	Vendor Name	Check Date	Invoice Number	Invoice Desc	PO Number	Invoice Amount	Check Amount
			TEACH	TEACH GRANT	0	11.08	
				TRAVEL TO CESA			
				10/11/02/2017			
10 E 800 348 221300 000			GENERAL FUND/INST. STAFF SERV. - TRAINING/VEHICLE FUEL			11.08	
74636	VERIZON WIRELESS	12/04/2017	9796403013	ACCOUNT#	0	88.48	454.20
				287205598-00001			
10 E 800 355 263300 000			GENERAL FUND/PUBLIC INFORMATION/TELEPHONE			88.48	
			9796403014	ACCOUNT#	0	365.72	
				287205598-00002			
10 E 800 355 263300 000			GENERAL FUND/PUBLIC INFORMATION/TELEPHONE			365.72	
74637	WE ENERGIES	12/04/2017	GREENHOUSE	10/12/17-11/13/17	0	80.09	80.09
10 E 800 331 253300 000			GENERAL FUND/OPERATION OF BUILDINGS/GAS FOR HEAT			80.09	
74638	WISCONSIN ASSOCIATION OF SKILL	12/04/2017	S37541	2017-2018	4011718158	45.00	45.00
				SkillsUSA			
				Registration Fees			
10 E 800 940 161333 000			GENERAL FUND/VOC. INDUSTRIAL CLUBS OF AM./DUES & FEES			45.00	
74639	XCEL ENERGY	12/04/2017	HIGH SCHOOL	10/15/17-11/14/17	0	44.56	44.56
10 E 800 336 253300 000			GENERAL FUND/OPERATION OF BUILDINGS/ELECTRICITY OTHER T			44.56	
74640	SAM ZIER	12/04/2017	OFFICIAL	BOYS C-TEAM	0	40.00	40.00
				BASKETBALL			
				12-05-2017			
10 E 400 310 162205 000			GENERAL FUND/BOYS BASKETBALL/PERSONAL SERVICES			40.00	

37 Computer Check(s) For a Total of 21,979.15

Check Nbr	Vendor Name	Check Date	Invoice Number	Invoice Desc	PO Number	Invoice Amount	Check Amount
74641	UNEMPLOYMENT INSURANCE	12/08/2017	8715213	ACCOUNT NO: 696072-000-8 NOVEMBER 2017 UNEMPLOYMENT	0	589.00	589.00
10 E 800 730 270000 000				GENERAL FUND/INSURANCE/UNEMPLOYMENT COMPENSATION		589.00	
74642	MADISON NATIONAL LIFE	12/08/2017	1276009	DECEMBER SHORT TERM DISABILITY	0	243.60	1,651.43
10 L 000 000 811635 000				GENERAL FUND/DISABILITY		181.44	
27 L 000 000 811635 000				SPECIAL EDUC./DISABILITY		62.16	
			1276010	DECEMBER LONG TERM DISABILITY	0	1,407.83	
10 E 800 251 120000 000				GENERAL FUND/REGULAR CURRICULUM/INCOME PROTECTION INSUR		6.59	
10 E 800 251 222000 000				GENERAL FUND/EDUCATIONAL MEDIA/INCOME PROTECTION INSURA		34.02	
10 E 800 251 232100 000				GENERAL FUND/OFFICE OF SUPERINTENDENT/INCOME PROTECTION		36.64	
10 E 800 251 252000 000				GENERAL FUND/FISCAL/INCOME PROTECTION INSURANCE		26.96	
10 E 800 251 253300 000				GENERAL FUND/OPERATION OF BUILDINGS/INCOME PROTECTION I		91.55	
27 E 100 251 158100 011				SPECIAL EDUC./MULTICATEGORICAL HANDICAPPED/INCOME PROTE		23.62	
27 E 400 251 158100 011				SPECIAL EDUC./MULTICATEGORICAL HANDICAPPED/INCOME PROTE		38.66	
27 E 800 251 156600 011				SPECIAL EDUC./SPEECH/LANGUAGE/INCOME PROTECTION INSURAN		27.75	
27 E 800 251 215000 011				SPECIAL EDUC./PSYCHOLOGICAL SERVICES/INCOME PROTECTION		10.15	
27 E 800 251 223300 011				SPECIAL EDUC./EEN DIRECTOR/INCOME PROTECTION INSURANCE		12.08	
50 E 800 251 257220 000				FOOD SERVICE FUND/FOOD SERVICE-LUNCH PROGRAM/INCOME PRO		41.60	
27 E 200 251 158100 011				SPECIAL EDUC./MULTICATEGORICAL HANDICAPPED/INCOME PROTE		24.53	
27 E 100 251 159300 011				SPECIAL EDUC./ADAPTIVE PHY ED/INCOME PROTECTION INSURAN		1.41	
10 E 800 251 266000 000				GENERAL FUND/TECHNOLOGY COORD/PROJECTS/INCOME PROTECTIO		1.69	
10 E 050 251 110000 000				GENERAL FUND/ELEMENTARY CURRICULUM/INCOME PROTECTION IN		16.46	
10 E 800 251 215000 000				GENERAL FUND/PSYCHOLOGICAL SERVICES/INCOME PROTECTION I		1.93	
10 E 100 251 110000 000				GENERAL FUND/ELEMENTARY CURRICULUM/INCOME PROTECTION IN		184.73	
10 E 100 251 110000 332				GENERAL FUND/ELEMENTARY CURRICULUM/INCOME PROTECTION IN		54.84	
10 E 200 251 120000 000				GENERAL FUND/REGULAR CURRICULUM/INCOME PROTECTION INSUR		144.27	
10 E 200 251 141000 000				GENERAL FUND/HEALTH/INCOME PROTECTION INSURANCE		6.72	
10 E 200 251 143000 000				GENERAL FUND/PHYSICAL EDUCATION/INCOME PROTECTION INSUR		10.07	
10 E 100 251 143000 000				GENERAL FUND/PHYSICAL EDUCATION/INCOME PROTECTION INSUR		12.69	
10 E 200 251 213000 000				GENERAL FUND/PUPIL SERVICES - GUIDANCE/INCOME PROTECTIO		10.76	
27 E 200 251 213000 011				SPECIAL EDUC./PUPIL SERVICES - GUIDANCE/INCOME PROTECTI		1.20	
10 E 100 251 213000 000				GENERAL FUND/PUPIL SERVICES - GUIDANCE/INCOME PROTECTIO		13.91	
27 E 100 251 213000 011				SPECIAL EDUC./PUPIL SERVICES - GUIDANCE/INCOME PROTECTI		1.55	
10 E 200 251 122000 141				GENERAL FUND/ENGLISH/INCOME PROTECTION INSURANCE		14.94	
10 E 100 251 122000 141				GENERAL FUND/ENGLISH/INCOME PROTECTION INSURANCE		16.93	
10 E 901 251 122000 141				GENERAL FUND/ENGLISH/INCOME PROTECTION INSURANCE		2.19	
27 E 800 251 223300 341				SPECIAL EDUC./EEN DIRECTOR/INCOME PROTECTION INSURANCE		2.53	
10 E 100 251 121000 000				GENERAL FUND/ART/INCOME PROTECTION INSURANCE		15.22	
10 E 200 251 121000 000				GENERAL FUND/ART/INCOME PROTECTION INSURANCE		6.91	
10 E 400 251 121000 000				GENERAL FUND/ART/INCOME PROTECTION INSURANCE		6.90	
10 E 400 251 124000 000				GENERAL FUND/MATHEMATICS/INCOME PROTECTION INSURANCE		24.89	
10 E 100 251 125100 000				GENERAL FUND/MUSICAL GENERAL/INCOME PROTECTION INSURANC		14.53	
10 E 200 251 125400 000				GENERAL FUND/VOCAL MUSIC/INCOME PROTECTION INSURANCE		6.75	
10 E 400 251 125400 000				GENERAL FUND/VOCAL MUSIC/INCOME PROTECTION INSURANCE		6.74	

Check Nbr	Vendor Name	Check Date	Invoice Number	Invoice Desc	PO Number	Invoice Amount	Check Amount
10 E 200 251 125500 000				GENERAL FUND/INSTRUMENTAL MUSIC/INCOME PROTECTION INSUR		4.99	
10 E 400 251 125500 000				GENERAL FUND/INSTRUMENTAL MUSIC/INCOME PROTECTION INSUR		4.98	
10 E 400 251 126000 000				GENERAL FUND/SCIENCE/INCOME PROTECTION INSURANCE		30.00	
10 E 400 251 127000 000				GENERAL FUND/SOCIAL STUDIES/INCOME PROTECTION INSURANCE		22.36	
10 E 400 251 122000 000				GENERAL FUND/ENGLISH/INCOME PROTECTION INSURANCE		23.62	
10 E 800 251 123000 000				GENERAL FUND/FOREIGN LANGUAGE/INCOME PROTECTION INSURAN		10.18	
10 E 400 251 132000 000				GENERAL FUND/BUSINESS EDUCATION/INCOME PROTECTION INSUR		5.49	
10 E 100 251 132000 000				GENERAL FUND/BUSINESS EDUCATION/INCOME PROTECTION INSUR		2.74	
10 E 200 251 132000 000				GENERAL FUND/BUSINESS EDUCATION/INCOME PROTECTION INSUR		2.74	
10 E 400 251 131000 000				GENERAL FUND/AGRICULTURE/INCOME PROTECTION INSURANCE		5.09	
10 E 200 251 131000 000				GENERAL FUND/AGRICULTURE/INCOME PROTECTION INSURANCE		5.09	
10 E 100 251 241000 000				GENERAL FUND/OFFICE OF PRINCIPAL/INCOME PROTECTION INSU		19.84	
10 E 200 251 241000 000				GENERAL FUND/OFFICE OF PRINCIPAL/INCOME PROTECTION INSU		37.69	
10 E 400 251 241000 000				GENERAL FUND/OFFICE OF PRINCIPAL/INCOME PROTECTION INSU		39.44	
10 E 400 251 135000 000				GENERAL FUND/FAMILY & CONSUMER EC/INCOME PROTECTION INS		1.95	
10 E 200 251 135000 000				GENERAL FUND/FAMILY & CONSUMER EC/INCOME PROTECTION INS		1.95	
10 E 800 251 110000 341				GENERAL FUND/ELEMENTARY CURRICULUM/INCOME PROTECTION IN		7.11	
27 E 100 251 159100 011				SPECIAL EDUC./EEN AIDES/INCOME PROTECTION INSURANCE		14.57	
27 E 200 251 159100 011				SPECIAL EDUC./EEN AIDES/INCOME PROTECTION INSURANCE		32.95	
27 E 400 251 159100 011				SPECIAL EDUC./EEN AIDES/INCOME PROTECTION INSURANCE		20.70	
10 E 400 251 141000 000				GENERAL FUND/HEALTH/INCOME PROTECTION INSURANCE		3.34	
10 E 400 251 143000 000				GENERAL FUND/PHYSICAL EDUCATION/INCOME PROTECTION INSUR		8.58	
27 E 050 251 152000 011				SPECIAL EDUC./EARLY CHILDHOOD/INCOME PROTECTION INSURAN		16.46	
10 E 400 251 136000 000				GENERAL FUND/TECH ED/INCOME PROTECTION INSURANCE		18.10	
10 E 200 251 136000 000				GENERAL FUND/TECH ED/INCOME PROTECTION INSURANCE		4.12	
10 E 400 251 213000 000				GENERAL FUND/PUPIL SERVICES - GUIDANCE/INCOME PROTECTIO		14.08	
27 E 200 251 159100 341				SPECIAL EDUC./EEN AIDES/INCOME PROTECTION INSURANCE		6.23	
27 E 400 251 213000 011				SPECIAL EDUC./PUPIL SERVICES - GUIDANCE/INCOME PROTECTI		1.56	
10 E 100 251 124000 000				GENERAL FUND/MATHEMATICS/INCOME PROTECTION INSURANCE		12.50	
10 E 100 251 122000 000				GENERAL FUND/ENGLISH/INCOME PROTECTION INSURANCE		28.41	
10 E 800 251 171000 391				GENERAL FUND/CULTURAL/SOCIALLY DISADVANTAGE/INCOME PROT		3.32	
10 E 800 251 171000 000				GENERAL FUND/CULTURAL/SOCIALLY DISADVANTAGE/INCOME PROT		38.07	
10 E 800 251 229000 000				GENERAL FUND/INSTRUCTIONAL STAFF SERVICES/INCOME PROTEC		4.67	

2

Computer

Check(s) For a Total of

2,240.43

Check Nbr	Vendor Name	Check Date	Invoice Number	Invoice Desc	PO Number	Invoice Amount	Check Amount
74643	AUDRA BROOKS	12/11/2017	REIMBURSEMENT	MILEAGE BAIRD CONFERENCE - 50 MILES GAS 12/5/17	0	70.14	70.14
10 E 800 342 252000 000			GENERAL FUND/FISCAL/EMPLOYEE TRAVEL & EXP.			70.14	
74644	DESIGNER ADVERTISING	12/11/2017	51413	WOMENS REVERSIBLE PRACTICE JERSEYS	8010171816	435.00	435.00
10 E 400 420 162105 000			GENERAL FUND/GIRLS BASKETBALL/APPAREL			435.00	
74645	PAUL KNETTER	12/11/2017	OFFICIAL	BOYS MS BASKETBALL 12-14-2017	0	62.00	62.00
10 E 200 310 162205 000			GENERAL FUND/BOYS BASKETBALL/PERSONAL SERVICES			62.00	
74646	PAUL KNETTER	12/11/2017	OFFICIAL	BOYS MS BASKETBALL 12-12-2017	0	82.00	82.00
10 E 200 310 162205 000			GENERAL FUND/BOYS BASKETBALL/PERSONAL SERVICES			82.00	
74647	KOLDEN, STEVEN E	12/11/2017	OCT & NOV 2017	MILEAGE 606 MILES	0	324.21	324.21
10 E 800 342 232100 000			GENERAL FUND/OFFICE OF SUPERINTENDENT/EMPLOYEE TRAVEL &			324.21	
74648	PATTI RAU	12/11/2017	REIMBURSEMENT	FLOOR MATS FOR VANS	0	192.80	192.80
10 E 800 411 254500 000			GENERAL FUND/MAINTENANCE-VEHICLES/GENERAL SUPPLIES			192.80	
74649	TREY RAU	12/11/2017	OFFICIAL	BOYS MS BASKETBALL 12-14-2017	0	62.00	62.00
10 E 200 310 162205 000			GENERAL FUND/BOYS BASKETBALL/PERSONAL SERVICES			62.00	
74650	TREY RAU	12/11/2017	OFFICIAL	BOYS MS BASKETBALL 12-12-2017	0	82.00	82.00
10 E 200 310 162205 000			GENERAL FUND/BOYS BASKETBALL/PERSONAL SERVICES			82.00	
				8 Computer	Check(s) For a Total of	1,310.15	

Check Nbr	Vendor Name	Check Date	Invoice Number	Invoice Desc	PO Number	Invoice Amount	Check Amount
74651	ADVANCED DISPOSAL	12/14/2017	M10000895299	TRASH AND RECYCLING SERVICES	0	671.60	671.60
10 E 800 320 253300 000				GENERAL FUND/OPERATION OF BUILDINGS/PROPERTY SERVICE		671.60	
74652	ALICE TRAINING INSTITUTE LLC	12/14/2017	24320	ELEARNING USERS(K12) - ADDITIONAL LICENSES	0	69.90	69.90
10 E 800 480 221300 000				GENERAL FUND/INST. STAFF SERV. - TRAINING/NON-INSTRUCT		69.90	
74653	AMERICAN WELDING & GAS INC	12/14/2017	05220354	Gas for welders, oxy and acten. Welding supplies TBD as needed during the school year. Tank Leasing	4011718130	263.05	464.18
10 E 400 411 136000 000				GENERAL FUND/TECH ED/GENERAL SUPPLIES		263.05	
			05220674	CYLINDER RENTAL - POOL	0	44.72	
10 E 800 411 253300 000				GENERAL FUND/OPERATION OF BUILDINGS/GENERAL SUPPLIES		44.72	
			05230899	CARBON DIOXIDE - POOL	0	156.41	
10 E 800 411 253300 000				GENERAL FUND/OPERATION OF BUILDINGS/GENERAL SUPPLIES		156.41	
74654	VIL DORCHESTER/FAYE AMO	12/14/2017	STEP	STEP HOURS WORKED: 32	0	232.00	232.00
80 E 800 310 232200 000				COMMUNITY SERVICE FUND/COMMUNITY RELATIONS/PERSONAL SER		232.00	
74655	[REDACTED]	12/14/2017	10/16/17-11/24/17	STW - COUNTY MARKET - 29.75 HOURS	0	29.75	29.75
27 E 800 185 158100 341				SPECIAL EDUC./MULTICATEGORICAL HANDICAPPED/SALARY STUDE		29.75	
74656	[REDACTED]	12/14/2017	NOVEMBER 2017	STW - 16.5 HOURS	0	16.50	16.50
27 E 800 185 158100 341				SPECIAL EDUC./MULTICATEGORICAL HANDICAPPED/SALARY STUDE		16.50	
74657	MARLENE ROBINSON BEDNAR	12/14/2017	NOVEMBER 2017	PUPIL HEALTH SERVICES - 4.5 HOURS @ \$28/HR	0	126.00	126.00
10 E 800 310 214000 000				GENERAL FUND/PUPIL HEALTH SERVICES/PERSONAL SERVICES		126.00	
74658	RENEE BRANDNER	12/14/2017	REIMBURSEMENT	REIMBURSE LUNCH ACCOUNT BALANCE	0	19.60	19.60
50 R 800 251 257220 000				FOOD SERVICE FUND/FOOD SERVICE-LUNCH PROGRAM/PUPILS		19.60	
74659	Vendor Continued Void	12/14/2017					0.00

Check Nbr	Vendor Name	Check Date	Invoice Number	Invoice Desc	PO Number	Invoice Amount	Check Amount
74660	BURNETT TRANSIT, INC.	12/14/2017	117.1	7TH AND 8TH GRADE TO UWSP - STEM	0	360.43	76,681.13
10 E 800 341 256742 000				GENERAL FUND/CO-CURRICULAR PUPIL TRANSPORTA/PUPIL TRAVE		360.43	
			126.0	SHOW CHOIR TO CHIPPEWA FALLS	0	424.77	
10 E 800 341 256742 000				GENERAL FUND/CO-CURRICULAR PUPIL TRANSPORTA/PUPIL TRAVE		424.77	
			128.0	SWIM TO UWSP	0	402.55	
10 E 800 341 256743 000				GENERAL FUND/ATHLETIC PUPIL TRANSPORTATION/PUPIL TRAVEL		402.55	
			25.0	1ST GRADE TO LUCILLE TACK CENTER	0	81.51	
10 E 800 341 256770 000				GENERAL FUND/FIELD TRIP TRANSPORTATION/PUPIL TRAVEL		81.51	
			41.3	MS BBB TO MARSHFIELD COLUMBUS	0	156.03	
10 E 800 341 256743 000				GENERAL FUND/ATHLETIC PUPIL TRANSPORTATION/PUPIL TRAVEL		156.03	
			41.5	BBB TO STRATFORD	0	160.68	
10 E 800 341 256743 000				GENERAL FUND/ATHLETIC PUPIL TRANSPORTATION/PUPIL TRAVEL		160.68	
			44.4	LIFE SKILLS CLASS TO ZIMMERMAN'S GOAT FARM	0	198.78	
27 E 800 341 256770 341				SPECIAL EDUC./FIELD TRIP TRANSPORTATION/PUPIL TRAVEL		198.78	
			45.4	GBB TO MARSHFIELD COLUMBUS	0	190.59	
10 E 800 341 256743 000				GENERAL FUND/ATHLETIC PUPIL TRANSPORTATION/PUPIL TRAVEL		190.59	
			49.8	5TH AND 6TH GRADE TO MELODY GARDENS	0	334.98	
10 E 800 341 256770 000				GENERAL FUND/FIELD TRIP TRANSPORTATION/PUPIL TRAVEL		334.98	
			52.2	MS BBB TO OWEN WITHEE	0	167.08	
10 E 800 341 256743 000				GENERAL FUND/ATHLETIC PUPIL TRANSPORTATION/PUPIL TRAVEL		167.08	
			59.0	MS BBB TO THORP	0	175.34	
10 E 800 341 256743 000				GENERAL FUND/ATHLETIC PUPIL TRANSPORTATION/PUPIL TRAVEL		175.34	
			6262	5TH OF 9 MONTHLY INVOICES - JANUARY 2018	0	66,900.00	
10 E 800 341 256710 000				GENERAL FUND/FLEET PUPIL TRANSPORTATION/PUPIL TRAVEL		66,900.00	
			6275	SOAR	0	1,212.00	

Check Nbr	Vendor Name	Check Date	Invoice Number	Invoice Desc	PO Number	Invoice Amount	Check Amount
27 E 800 341 256751 011				SPECIAL EDUC./EEN PUPIL TRANSPORTATION/PUPIL TRAVEL		1,212.00	
			6296	SHORT BUS 20 DAYS	0	4,615.78	
10 E 800 341 256710 000				GENERAL FUND/FLEET PUPIL TRANSPORTATION/PUPIL TRAVEL		4,615.78	
			6296-1	SHORT BUS 20 DAYS MILEAGE 1708.3 @ .64	0	1,093.31	
10 E 800 341 256710 000				GENERAL FUND/FLEET PUPIL TRANSPORTATION/PUPIL TRAVEL		1,093.31	
			66.0	MS BBB TO STANLEY-BOYD	0	207.30	
10 E 800 341 256743 000				GENERAL FUND/ATHLETIC PUPIL TRANSPORTATION/PUPIL TRAVEL		207.30	
74661 BUSHMAN DAIRY DISTRIBUTORS		12/14/2017	L-278503	COTTAGE CHEESE	0	212.50	212.50
50 E 800 415 257220 000				FOOD SERVICE FUND/FOOD SERVICE-LUNCH PROGRAM/FOOD		212.50	
74662 CESA #10		12/14/2017	8337	SERVBILL2	0	31,459.50	31,459.50
10 E 800 386 221200 000				GENERAL FUND/CURRICULUM DEVELOPMENT/PAYMENT TO CESA		7,975.00	
10 E 800 386 253300 000				GENERAL FUND/OPERATION OF BUILDINGS/PAYMENT TO CESA		764.50	
10 E 800 386 266000 000				GENERAL FUND/TECHNOLOGY COORD/PROJECTS/PAYMENT TO CESA		4,425.00	
10 E 800 386 299000 000				GENERAL FUND/OTHER SUPPORT SERVICES/PAYMENT TO CESA		547.00	
27 E 800 386 436670 019				SPECIAL EDUC./CESA VISION SERV./PAYMENT TO CESA		9,347.25	
27 E 800 386 218200 019				SPECIAL EDUC./PHYSICAL THERAPY/PAYMENT TO CESA		8,100.75	
10 E 800 386 219000 000				GENERAL FUND/OTHER PUPIL SERVICES/PAYMENT TO CESA		300.00	
74663 CHESTNUT CONSULTING		12/14/2017	MSP-3240	TECHNOLOGY SERVICE AGREEMENT	0	8,250.00	8,250.00
10 E 800 310 266000 000				GENERAL FUND/TECHNOLOGY COORD/PROJECTS/PERSONAL SERVICE		8,250.00	
74664 CITY OF COLBY		12/14/2017	ADAMS HOUSE	10/16/17-11/15/17	0	34.10	2,421.05
10 E 800 337 253300 000				GENERAL FUND/OPERATION OF BUILDINGS/WATER SERVICE		34.10	
				CONCESSION STAND 10/16/17-11/15/17	0	86.70	
10 E 800 337 253300 000				GENERAL FUND/OPERATION OF BUILDINGS/WATER SERVICE		86.70	
				ELEMENTARY SCHOOL 10/16/17-11/15/17	0	690.55	
10 E 800 337 253300 000				GENERAL FUND/OPERATION OF BUILDINGS/WATER SERVICE		690.55	
				HIGH SCHOOL 10/16/17-11/15/17	0	1,181.30	
10 E 800 337 253300 000				GENERAL FUND/OPERATION OF BUILDINGS/WATER SERVICE		1,181.30	
				MIDDLE SCHOOL 10/16/17-11/15/17	0	428.40	
10 E 800 337 253300 000				GENERAL FUND/OPERATION OF BUILDINGS/WATER SERVICE		428.40	
74665 Vendor Continued Void		12/14/2017					0.00
74666 Vendor Continued Void		12/14/2017					0.00
74667 COUNTY MARKET ACCOUNT #6017		12/14/2017	001008221344	rewards	6021718028	9.26	605.39
27 E 400 415 158100 341				SPECIAL EDUC./MULTICATEGORICAL HANDICAPPED/FOOD		9.26	

Check Nbr	Vendor Name	Check Date	Invoice Number	Invoice Desc	PO Number	Invoice Amount	Check Amount
			001043691407	Food for Life Skills and Math Classes	6021718057	53.70	
27 E 400 415 158100 341				SPECIAL EDUC./MULTICATEGORICAL HANDICAPPED/FOOD		53.70	
			001047261603	Supplies	4011718062	17.50	
10 E 400 411 126000 000				GENERAL FUND/SCIENCE/GENERAL SUPPLIES		17.50	
			001069911343	Food for Life Skills and Math Classes	6021718057	22.56	
27 E 400 415 158100 341				SPECIAL EDUC./MULTICATEGORICAL HANDICAPPED/FOOD		22.56	
			001070071422	groceries for baking project special ed k-3	6021718087	73.53	
27 E 100 415 158100 341				SPECIAL EDUC./MULTICATEGORICAL HANDICAPPED/FOOD		73.53	
			002000130852	Open PO to purchase grocery kitchen items to use during life skills/math/Readin g class to meet student IEP objectives	6021718045	82.93	
27 E 200 415 158100 341				SPECIAL EDUC./MULTICATEGORICAL HANDICAPPED/FOOD		82.93	
			003000221013	purchase grocery/kitchen items to be used in Life Skills/Math/Readin g classes to meet student IEP objectives	6021718034	9.02	
27 E 400 415 158100 341				SPECIAL EDUC./MULTICATEGORICAL HANDICAPPED/FOOD		9.02	
			003000301638	2017-2018 HS AG:seeds, food and other supplies for classroom	4011718079	15.92	
10 E 400 411 131000 000				GENERAL FUND/AGRICULTURE/GENERAL SUPPLIES		6.82	
10 E 400 415 131000 000				GENERAL FUND/AGRICULTURE/FOOD		9.10	
			003000431500	BOE MEETING	0	128.98	
10 E 800 415 231100 000				GENERAL FUND/BOARD OF EDUCATION/FOOD		128.98	
			007000190701	2017-2018 HS	4011718079	163.47	

Check Nbr	Vendor Name	Check Date	Invoice Number	Invoice Desc	PO Number	Invoice Amount	Check Amount
10 E 400 411 131000 000				AG:seeds, food and other supplies for classroom		70.06	
10 E 400 415 131000 000				GENERAL FUND/AGRICULTURE/GENERAL SUPPLIES		93.41	
			007000350706	2017-2018 HS AG:seeds, food and other supplies for classroom	0	15.53	
50 E 800 415 257220 000				FOOD SERVICE FUND/FOOD SERVICE-LUNCH PROGRAM/FOOD		15.53	
			007001261059	COMMUNITY ED - SUP	0	12.99	
80 E 800 411 232200 000				COMMUNITY SERVICE FUND/COMMUNITY RELATIONS/GENERAL SUPP		12.99	
74668 COUNTY MARKET - F&CE ACCT 8007		12/14/2017	NOVEMBER 2017	FOOD SUPPLIES	4011718009	396.28	396.28
10 E 400 415 135000 000				GENERAL FUND/FAMILY & CONSUMER EC/FOOD		396.28	
74669 DEAN FOODS OF WISCONSIN		12/14/2017	NOVEMBER 2017	MILK	0	4,595.69	4,595.69
50 E 800 415 257220 000				FOOD SERVICE FUND/FOOD SERVICE-LUNCH PROGRAM/FOOD		4,595.69	
74670 DEMCO		12/14/2017	6264491	2017-2018 - HS - 411 - Demco	2001718064	92.47	92.47
10 E 400 411 222200 000				GENERAL FUND/LMC - INST SERVICE/GENERAL SUPPLIES		92.47	
74671 WI DEPT OF PUBLIC INSTRUCTION		12/14/2017	WISCAT143011	2017-2018 - HS - 435 - WISCAT	2001718048	200.00	600.00
10 E 400 435 222200 000				GENERAL FUND/LMC - INST SERVICE/PROGRAMMED COMPUTER SOF		200.00	
			WISCAT143021	2017-2018 -CE - 435 - WISCAT	2001718048	200.00	
10 E 100 435 222200 000				GENERAL FUND/LMC - INST SERVICE/PROGRAMMED COMPUTER SOF		200.00	
			WISCAT143026	2017-2018 - MS - 435 - WISCAT	2001718048	200.00	
10 E 200 435 222200 000				GENERAL FUND/LMC - INST SERVICE/PROGRAMMED COMPUTER SOF		200.00	
74672 FAMILY, CAREER & COMMUNITY LEA		12/14/2017	55486	2017-2018 FCCLA: National, State, and Regional FCCLA dues, fees, and registration	4011718006	29.00	197.00
10 E 800 940 161312 000				GENERAL FUND/FCCLA/DUES & FEES		29.00	
			55793	2017-2018 FCCLA: National, State, and Regional FCCLA dues, fees,	4011718006	168.00	

Check Nbr	Vendor Name	Check Date	Invoice Number	Invoice Desc	PO Number	Invoice Amount	Check Amount
				and registration			
10 E 800 940 161312 000				GENERAL FUND/FCCLA/DUES & FEES		168.00	
74673	CITY OF COLBY/LORRAINE FISCHER	12/14/2017	STEP	STEP HOURS WORKED: 55.75	0	404.19	404.19
80 E 800 310 232200 000				COMMUNITY SERVICE FUND/COMMUNITY RELATIONS/PERSONAL SER		404.19	
74674	FOURMENS FARM HOME - COLBY	12/14/2017	3-46171	COUPLER FEMALE, HOSE FITTING MALE, CLAMP	0	13.95	106.33
10 E 800 411 254300 000				GENERAL FUND/MAINTENANCE-BUILDINGS/GENERAL SUPPLIES		13.95	
			3-46974	CARRIAGE BOLTS, ANTIFREEZE, WINDSHIELD WASHER FLUID	0	12.78	
10 E 800 411 254300 000				GENERAL FUND/MAINTENANCE-BUILDINGS/GENERAL SUPPLIES		12.78	
			3-48045	LAMPHOLDER CEILING KEYLESS	0	1.99	
10 E 800 411 254300 000				GENERAL FUND/MAINTENANCE-BUILDINGS/GENERAL SUPPLIES		1.99	
			3-48583	BATTERY ALK PRO PK AA	0	15.81	
10 E 800 411 254300 000				GENERAL FUND/MAINTENANCE-BUILDINGS/GENERAL SUPPLIES		15.81	
			3-48629	SLIM 10-120 DUAL HEAD TIRE GA, TOILET PAPER CHARMIN	0	12.43	
10 E 800 411 254300 000				GENERAL FUND/MAINTENANCE-BUILDINGS/GENERAL SUPPLIES		12.43	
			3-48819	DRIVEWAY MARKER, RESPIRATOR SANDING.FIBERGLASS	0	33.38	
10 E 800 411 254300 000				GENERAL FUND/MAINTENANCE-BUILDINGS/GENERAL SUPPLIES		33.38	
			3-50575	SAWXALL BL 24T 6LG TORCH 5PK	0	15.99	
10 E 800 411 254300 000				GENERAL FUND/MAINTENANCE-BUILDINGS/GENERAL SUPPLIES		15.99	
74675	FRONTIER	12/14/2017	11-28-17-12/27/17	ACCOUNT # 262-159-0899-09041 4-5	0	109.01	109.01
10 E 800 355 263300 000				GENERAL FUND/PUBLIC INFORMATION/TELEPHONE		109.01	
74676	GREG GRUETT'S APPLIANCE LLC	12/14/2017	4557	SPEED QUEEN FRONT LOAD WASHER AND PEDESTAL	0	1,649.98	1,649.98
10 E 800 440 253300 000				GENERAL FUND/OPERATION OF BUILDINGS/NON-CAPITAL EQUIPME		1,649.98	

Check Nbr	Vendor Name	Check Date	Invoice Number	Invoice Desc	PO Number	Invoice Amount	Check Amount
74677	GUITAR CENTER	12/14/2017	ARINV38890630	Replacement of piano and amps for elementary music department.	1021718065	399.98	999.97
10 E 100 440 125400 000			GENERAL FUND/VOCAL MUSIC/NON-CAPITAL EQUIPMENT			399.98	
			ARINV38898954	Replacement of piano and amps for elementary music department.	1021718065	599.99	
10 E 100 440 125400 000			GENERAL FUND/VOCAL MUSIC/NON-CAPITAL EQUIPMENT			599.99	
74678	TOWN OF GREEN GROVE/JOYCE HAMA	12/14/2017	STEP	STEP HOURS WORKED: 69.75	0	478.50	478.50
80 E 800 310 232200 000			COMMUNITY SERVICE FUND/COMMUNITY RELATIONS/PERSONAL SER			478.50	
74679	INDIANHEAD FOODSERVICE DISTRIB	12/14/2017	NOVEMBER 2017	FOOD & SUPPLIES	0	12,427.13	12,688.93
50 E 800 415 257220 000			FOOD SERVICE FUND/FOOD SERVICE-LUNCH PROGRAM/FOOD			9,856.68	
50 E 800 419 257220 000			FOOD SERVICE FUND/FOOD SERVICE-LUNCH PROGRAM/OTHER SUPP			698.31	
50 E 800 415 257225 000			FOOD SERVICE FUND/BREAKFAST PROGRAM/FOOD			1,812.41	
50 E 800 419 257225 000			FOOD SERVICE FUND/BREAKFAST PROGRAM/OTHER SUPPLIES			59.73	
			NOVEMBER 2017 COMM	FOOD - COMMODITIES	0	261.80	
50 E 800 415 257220 000			FOOD SERVICE FUND/FOOD SERVICE-LUNCH PROGRAM/FOOD			261.80	
74680	IRONWORKER LLC	12/14/2017	53921	BLADE	1011718017	810.32	810.32
10 E 400 440 136000 000			GENERAL FUND/TECH ED/NON-CAPITAL EQUIPMENT			810.32	
74681	DENNIS OR RHONDA KIEFFER	12/14/2017	NOVEMBER 2017	ACA MILEAGE - 192 MILES	0	61.44	61.44
10 E 800 341 256730 000			GENERAL FUND/PARENT TRANSPORTATION/PUPIL TRAVEL			61.44	
74682	KURT OR HEATHER KULAS	12/14/2017	NOVEMBER 2017	ACA MILEAGE - 96 MILES	0	30.72	30.72
10 E 800 341 256730 000			GENERAL FUND/PARENT TRANSPORTATION/PUPIL TRAVEL			30.72	
74683	MARSHFIELD BOOK & STATIONARY	12/14/2017	346355	Poster Board	4011718176	281.96	1,539.17
10 E 400 411 124000 000			GENERAL FUND/MATHEMATICS/GENERAL SUPPLIES			281.96	
			346373	MAGAZINE FILE	3020161707	54.49	
10 E 800 411 223910 000			GENERAL FUND/READING SPECIALIST/GENERAL SUPPLIES			54.49	
			346392	math supplies	6021718044	90.72	
27 E 200 411 158100 341			SPECIAL EDUC./MULTICATEGORICAL HANDICAPPED/GENERAL SUPP			90.72	
			346448	CHAIRS FOR MS CONFERENCE ROOM	1011718016	1,112.00	
10 E 200 440 241000 000			GENERAL FUND/OFFICE OF PRINCIPAL/NON-CAPITAL EQUIPMENT			1,112.00	

Check Nbr	Vendor Name	Check Date	Invoice Number	Invoice Desc	PO Number	Invoice Amount	Check Amount
74684	MARSHFIELD CLINIC	12/14/2017	ACCOUT # 8-008-730	EMPLOYMENT PHYSICALS	0	64.40	64.40
10 E 800 310 264500 000				GENERAL FUND/STAFF HEALTH SERVICES/PERSONAL SERVICES		64.40	
74685	NEFF COMPANY	12/14/2017	002607241	CHENILLE LETTER - CLASSIC - FULL BLOCK LETTER, CHENILLE- BAR	0	1,203.91	1,203.91
10 E 800 411 162001 000				GENERAL FUND/ATHLETICS-GENERAL/GENERAL SUPPLIES		1,203.91	
74686	PROVISION PARTNERS COOPERATIVE	12/14/2017	449822	COLBY SCHOOL DISTRICT GAS CHARGES - NOVEMBER 2017	0	254.88	254.88
27 E 400 348 158100 341				SPECIAL EDUC./MULTICATEGORICAL HANDICAPPED/VEHICLE FUEL		183.37	
10 E 400 348 162124 000				GENERAL FUND/GIRLS SWIMMING/VEHICLE FUEL		71.51	
74687	Vendor Continued Void	12/14/2017					0.00
74688	Vendor Continued Void	12/14/2017					0.00
74689	Vendor Continued Void	12/14/2017					0.00
74690	Vendor Continued Void	12/14/2017					0.00
74691	RCU CARDHOLDER SERVICES	12/14/2017	24000977311019900946	AMERICAN FLAGS FOR LESS	0	169.95	4,728.35
10 E 800 411 232100 000				GENERAL FUND/OFFICE OF SUPERINTENDENT/GENERAL SUPPLIES		169.95	
			2410847730390001722	GLACIER CANYON - KOLDEN	0	314.30	
10 E 800 342 232100 000				GENERAL FUND/OFFICE OF SUPERINTENDENT/EMPLOYEE TRAVEL &		314.30	
			24108477303900017229	GLACIER CANYON - KOLDEN	0	184.10	
10 E 800 342 232100 000				GENERAL FUND/OFFICE OF SUPERINTENDENT/EMPLOYEE TRAVEL &		184.10	
			2420785731432200475	WSRA MEMBERSHIP - J.PETERSON	1021718052	37.00	
10 E 100 310 221300 332				GENERAL FUND/INST. STAFF SERV. - TRAINING/PERSONAL SERV		37.00	
			24231687326083056250	Hand and Power tools for auto classes, welding classes, woods classes and metals classes	4011718132	708.41	
10 E 400 440 136000 000				GENERAL FUND/TECH ED/NON-CAPITAL EQUIPMENT		708.41	
			24426297312018029442	2018 STATE EDUCATION CONFRENCE - WASB	0	696.00	
10 E 800 310 231100 000				GENERAL FUND/BOARD OF EDUCATION/PERSONAL SERVICES		696.00	

Check Nbr	Vendor Name	Check Date	Invoice Number	Invoice Desc	PO Number	Invoice Amount	Check Amount
			24431067319083757239	AVERY BUSINESS CARDS	0	11.07	
10 E 800 411 232100 000				GENERAL FUND/OFFICE OF SUPERINTENDENT/GENERAL SUPPLIES		11.07	
			24431067324083304516	2017-2018 - CE - 440 - Amazon	2001718038	149.99	
10 E 100 440 222200 000				GENERAL FUND/LMC - INST SERVICE/NON-CAPITAL EQUIPMENT		149.99	
			24431067328083702614	WHITE 6 X9 ENVELOPES	0	38.85	
10 E 100 411 241000 000				GENERAL FUND/OFFICE OF PRINCIPAL/GENERAL SUPPLIES		38.85	
			24431673260833165869	LAPTOP BATTERY FOR HP ELITEBOOK 840	0	32.99	
10 E 800 411 266000 000				GENERAL FUND/TECHNOLOGY COORD/PROJECTS/GENERAL SUPPLIES		32.99	
			24492157307894913963	2017-18: Professional Membership Dues	4011718032	70.00	
10 E 400 940 213000 000				GENERAL FUND/PUPIL SERVICES - GUIDANCE/DUES & FEES		70.00	
			24559307331900149000	ASBO SFO STUDY GROUP - A. BROOKS	0	70.00	
10 E 800 310 252000 000				GENERAL FUND/FISCAL/PERSONAL SERVICES		70.00	
			24692167305200129763	CLIP DIDGITAL TIMER	0	23.97	
27 E 200 411 158100 341				SPECIAL EDUC./MULTICATEGORICAL HANDICAPPED/GENERAL SUPP		23.97	
			24692167306200758640	science lab supplies (411)	4011718027	8.99	
10 E 400 411 126000 000				GENERAL FUND/SCIENCE/GENERAL SUPPLIES		8.99	
			24692167311200905300	DOME FOOD COVERS, COLD FOOD PANS	0	523.56	
50 E 800 419 257220 000				FOOD SERVICE FUND/FOOD SERVICE-LUNCH PROGRAM/OTHER SUPP		523.56	
			24692167313200221840	STEP LADDERS	0	158.97	
10 E 100 411 241000 000				GENERAL FUND/OFFICE OF PRINCIPAL/GENERAL SUPPLIES		158.97	
			24692167314200931973	DISPLAYPORT TO HDMI ADAPTER	0	19.98	
10 E 800 411 266000 000				GENERAL FUND/TECHNOLOGY COORD/PROJECTS/GENERAL SUPPLIES		19.98	
			2469216731910026517	Re-fill filter pads for classroom fish tank filter.	4011718183	9.49	
10 E 400 411 131000 000				GENERAL FUND/AGRICULTURE/GENERAL SUPPLIES		9.49	

Check Nbr	Vendor Name	Check Date	Invoice Number	Invoice Desc	PO Number	Invoice Amount	Check Amount
			24692167319100265171	Filter for classroom fish tank	4011718180	22.49	
10 E 400 411 131000 000				GENERAL FUND/AGRICULTURE/GENERAL SUPPLIES		22.49	
			24692167319100390642	Pesticide for greenhouse	4011718181	26.00	
10 E 400 411 131000 000				GENERAL FUND/AGRICULTURE/GENERAL SUPPLIES		26.00	
			24692167320100790437	Pesticide for greenhouse	4011718182	19.88	
10 E 400 411 131000 000				GENERAL FUND/AGRICULTURE/GENERAL SUPPLIES		19.88	
			246921673221007685	2017-2018 - MS - Equipment - 440	2001718061	51.98	
10 E 200 440 222200 000				GENERAL FUND/LMC - INST SERVICE/NON-CAPITAL EQUIPMENT		51.98	
			2469216732210076855	2017-2018 - HS - Equipment - 440	2001718060	51.98	
10 E 400 440 222200 000				GENERAL FUND/LMC - INST SERVICE/NON-CAPITAL EQUIPMENT		51.98	
			24692167322100768557	2017-2018 - CE - Equipment - 440	2001718051	129.95	
10 E 100 440 222200 000				GENERAL FUND/LMC - INST SERVICE/NON-CAPITAL EQUIPMENT		129.95	
			24692167322100814366	STANDARD LOW NOISE CASE FANS, NEW CPU COLLOING FAN FOR HP ELITEBOOK 840 850	0	48.25	
10 E 800 411 266000 000				GENERAL FUND/TECHNOLOGY COORD/PROJECTS/GENERAL SUPPLIES		48.25	
			24692167324100421947	SAMSUNG SODIM MEMORY	0	29.99	
10 E 800 411 266000 000				GENERAL FUND/TECHNOLOGY COORD/PROJECTS/GENERAL SUPPLIES		29.99	
			24692167324100421980	25FT RCA MALE TO MALE	0	7.49	
10 E 800 411 266000 000				GENERAL FUND/TECHNOLOGY COORD/PROJECTS/GENERAL SUPPLIES		7.49	
			24692167327100884611	Protocols, online subscriptions, and updated test kits	6021718061	1,139.38	
27 E 800 411 215000 341				SPECIAL EDUC./PSYCHOLOGICAL SERVICES/GENERAL SUPPLIES		759.59	
27 E 800 439 215000 341				SPECIAL EDUC./PSYCHOLOGICAL SERVICES/OTHER MEDIA		379.79	
			24707807302018058742	SLEEP INN AND SUITES - L.SPICE	0	164.00	
10 E 800 342 221300 000				GENERAL FUND/INST. STAFF SERV. - TRAINING/EMPLOYEE TRAV		164.00	

Check Nbr	Vendor Name	Check Date	Invoice Number	Invoice Desc	PO Number	Invoice Amount	Check Amount
			24717057307417307304	DOJ BACKGROUND CHECK	0	7.00	
10 E 800 310 232100 000				GENERAL FUND/OFFICE OF SUPERINTENDENT/PERSONAL SERVICES		7.00	
			24717057319163197278	DOJ BACKGROUND CHECK	0	7.00	
10 E 800 310 232100 000				GENERAL FUND/OFFICE OF SUPERINTENDENT/PERSONAL SERVICES		7.00	
			24717057322263222384	DOJ BACKGROUND CHECK	0	7.00	
10 E 800 310 232100 000				GENERAL FUND/OFFICE OF SUPERINTENDENT/PERSONAL SERVICES		7.00	
			24906417312046609795	SMT2GO	0	139.00	
10 E 800 480 266000 000				GENERAL FUND/TECHNOLOGY COORD/PROJECTS/NON-INSTRUCT COM		139.00	
			74108477302900017027	GLACEIR CANYON - B. TESMER	0	-92.05	
10 E 800 342 231100 000				GENERAL FUND/BOARD OF EDUCATION/EMPLOYEE TRAVEL & EXP.		-92.05	
			74108477303900017829	GLACEIR CANYON - B. TESMER	0	-184.10	
10 E 800 342 231100 000				GENERAL FUND/BOARD OF EDUCATION/EMPLOYEE TRAVEL & EXP.		-184.10	
			74108477304900181313	GLACEIR CANYON - B. TESMER	0	-20.10	
10 E 800 342 231100 000				GENERAL FUND/BOARD OF EDUCATION/EMPLOYEE TRAVEL & EXP.		-20.10	
			7410847730590001863	CREDIT MEMO - GLACIER CANYON	0	-20.10	
10 E 800 342 232100 000				GENERAL FUND/OFFICE OF SUPERINTENDENT/EMPLOYEE TRAVEL &		-20.10	
			74108477305900018634	CREDIT MEMO - GLACIER CANYON	0	-34.31	
10 E 800 342 232100 000				GENERAL FUND/OFFICE OF SUPERINTENDENT/EMPLOYEE TRAVEL &		-34.31	
74692	DANIELLA SCHAUER	12/14/2017	MILEAGE	HIGH SCHOOL TO NTC AND BACK 73 MILES 08/11/16	0	39.42	39.42
50 E 800 342 264400 000				FOOD SERVICE FUND/STAFF TRAINING-NON-INSTRUCTION/EMPLOY		39.42	
74693	SECURITY HEALTH PLAN	12/14/2017	3620	COBRA Administration - November 2017	0	174.90	174.90
10 E 800 310 252000 000				GENERAL FUND/FISCAL/PERSONAL SERVICES		174.90	
74694	SECURITY HEALTH PLAN	12/14/2017	JAN2018	JANUARY 2018 HEALTH INSURANCE PREMIUM	0	162,094.66	162,094.66
10 L 000 000 811631 000				GENERAL FUND/HEALTH INSURANCE		124,642.13	
10 E 800 310 252000 000				GENERAL FUND/FISCAL/PERSONAL SERVICES		446.25	

Check Nbr	Vendor Name	Check Date	Invoice Number	Invoice Desc	PO Number	Invoice Amount	Check Amount
27 L 000 000 811631 000				SPECIAL EDUC./HEALTH INSURANCE		28,104.59	
50 L 000 000 811631 000				FOOD SERVICE FUND/HEALTH INSURANCE		8,812.61	
80 L 000 000 811631 000				COMMUNITY SERVICE FUND/HEALTH INSURANCE		89.08	
74695 SHOPKO		12/14/2017	7203	Shopko	6021718074	92.78	92.78
27 E 100 411 158100 341				SPECIAL EDUC./MULTICATEGORICAL HANDICAPPED/GENERAL SUPP		92.78	
74696 SJS		12/14/2017	410	LOAD UP CONCETE DISCUSS PADS, HAUL OUT CONCRETE, LEVEL TOPSOIL	0	625.00	625.00
10 E 800 320 254200 000				GENERAL FUND/MAINTENANCE-SITES/PROPERTY SERVICE		625.00	
74697 SYSCO BARABOO LLC		12/14/2017	NOVEMBER 2017	FOOD	0	1,537.74	1,537.74
50 E 800 415 257220 000				FOOD SERVICE FUND/FOOD SERVICE-LUNCH PROGRAM/FOOD		1,537.74	
74698 T & C WATER SYSTEMS		12/14/2017	32054	COOLER RENTAL	0	25.70	25.70
10 E 800 415 232100 000				GENERAL FUND/OFFICE OF SUPERINTENDENT/FOOD		25.70	
74699 TP PRINTING CO INC		12/14/2017	65628	HORNET HIGHLIGHTS - NOVEMBER	0	135.00	379.80
10 E 400 354 132000 000				GENERAL FUND/BUSINESS EDUCATION/PRINTING & BINDING		135.00	
			65629	DIPLAY ADS , SUBSCRIPTION RENEWAL	0	244.80	
10 E 800 354 263300 000				GENERAL FUND/PUBLIC INFORMATION/PRINTING & BINDING		244.80	
74700 [REDACTED]		12/14/2017	NOVEMBER 2017	STUDENT KITCHEN WORKER - 3.35 HOURS	0	3.35	17.12
27 E 800 185 158100 341				SPECIAL EDUC./MULTICATEGORICAL HANDICAPPED/SALARY STUDE		3.35	
				NOVEMBER 2017 - STW STW - 13.77 HOURS	0	13.77	
27 E 800 185 158100 341				SPECIAL EDUC./MULTICATEGORICAL HANDICAPPED/SALARY STUDE		13.77	
74701 WISCNET		12/14/2017	11071	WISCNET MEMBERSHIP FEE, LOCAL FILTERING ANNUAL HARDWARE FEE, LOCAL FILTERING USAGE FEE	0	5,400.00	5,400.00
10 E 800 358 266000 000				GENERAL FUND/TECHNOLOGY COORD/PROJECTS/ON-LINE COMMUNIC		5,400.00	
74702 JULIE WOLF		12/14/2017	REIMBURSEMENT	CASH FOR STUDENTS TO EAT FOR COMMUNITY OUTING	6021718073	84.00	84.00
27 E 400 940 158100 341				SPECIAL EDUC./MULTICATEGORICAL HANDICAPPED/DUES & FEES		84.00	

Check Nbr	Vendor Name	Check Date	Invoice Number	Invoice Desc	PO Number	Invoice Amount	Check Amount
52				Computer	Check(s) For a Total of		322,741.76

Obj	2016-17 Original Budget	2016-17 FYTD Activity	2016-17 FYTD %	2017-18 Budget	2017-18 FYTD Activity	2017-18 FYTD %	Encumbered Amount	Unencumbered Balance
100000	INSTRUCTION							
110000	ELEMENTARY CURRICULUM							
SALARIES	963,400.00	352,121.67	36.55	927,047.00	319,810.36	34.50	0.00	607,236.64
EMPLOYEE BENEFITS	561,482.00	218,817.06	38.97	536,795.00	158,485.69	29.52	0.00	378,309.31
PURCHASED SERVICES	300.00	30.24	10.08	0.00	0.00	0.00	0.00	0.00
NON-CAPITAL OBJECTS	25,260.00	19,327.58	76.51	21,790.00	22,180.39	101.79	1,124.56	-1,514.95
CAPITAL OBJECTS	0.00	0.00	0.00	0.00	0.00	0.00	0.00	0.00
OTHER OBJECTS	0.00	0.00	0.00	0.00	0.00	0.00	0.00	0.00
ELEMENTARY CURRICULUM	1,550,442.00	590,296.55	38.07	1,485,632.00	500,476.44	33.69	1,124.56	984,031.00
120000	REGULAR CURRICULUM							
SALARIES	1,581,174.00	601,310.54	38.03	1,664,057.00	559,789.90	33.64	0.00	1,104,267.10
EMPLOYEE BENEFITS	876,589.00	296,481.13	33.82	819,863.00	231,640.84	28.25	0.00	588,222.16
PURCHASED SERVICES	5,240.00	2,850.00	54.39	3,900.00	0.00	0.00	1,550.00	2,350.00
NON-CAPITAL OBJECTS	63,006.00	34,261.55	54.38	63,779.00	47,477.38	74.44	23,347.72	-7,046.10
CAPITAL OBJECTS	0.00	0.00	0.00	0.00	0.00	0.00	0.00	0.00
OTHER OBJECTS	5,040.00	1,926.00	38.21	4,536.00	2,145.00	47.29	4,426.00	-2,035.00
REGULAR CURRICULUM	2,531,049.00	936,829.22	37.01	2,556,135.00	841,053.12	32.90	29,323.72	1,685,758.16
130000	VOCATIONAL CURRICULUM							
SALARIES	181,254.00	69,364.58	38.27	193,372.00	64,019.24	33.11	0.00	129,352.76
EMPLOYEE BENEFITS	103,841.00	41,212.74	39.69	96,835.00	29,745.66	30.72	0.00	67,089.34
PURCHASED SERVICES	4,145.00	3,919.66	94.56	5,089.00	2,733.72	53.72	3,849.00	-1,493.72
NON-CAPITAL OBJECTS	28,448.00	14,299.51	50.27	39,823.00	21,776.29	54.68	21,491.07	-3,444.36
CAPITAL OBJECTS	0.00	92.00	0.00	100.00	0.00	0.00	0.00	100.00
OTHER OBJECTS	0.00	55.00	0.00	105.00	0.00	0.00	80.00	25.00
VOCATIONAL CURRICULUM	317,688.00	128,943.49	40.59	335,324.00	118,274.91	35.27	25,420.07	191,629.02
140000	PHYSICAL CURRICULUM							
SALARIES	146,305.00	59,542.79	40.70	159,530.00	59,450.83	37.27	0.00	100,079.17
EMPLOYEE BENEFITS	82,544.00	31,515.74	38.18	72,176.00	25,322.69	35.08	0.00	46,853.31
PURCHASED SERVICES	200.00	0.00	0.00	100.00	0.00	0.00	0.00	100.00
NON-CAPITAL OBJECTS	4,225.00	3,737.54	88.46	4,484.00	3,491.56	77.87	1,092.40	-99.96

Obj	2016-17		2016-17		2017-18		Encumbered Amount	Unencumbered Balance
	Original Budget	FYTD Activity	FYTD %	Budget	FYTD Activity	FYTD %		
100000	INSTRUCTION							
140000	PHYSICAL CURRICULUM							
CAPITAL OBJECTS	0.00	0.00	0.00	0.00	0.00	0.00	0.00	0.00
OTHER OBJECTS	4,230.00	0.00	0.00	4,400.00	0.00	0.00	3,600.00	800.00
PHYSICAL CURRICULUM	237,504.00	94,796.07	39.91	240,690.00	88,265.08	36.67	4,692.40	147,732.52
150000	SPECIAL CURRICULUM							
SALARIES	0.00	0.00	0.00	0.00	0.00	0.00	0.00	0.00
EMPLOYEE BENEFITS	0.00	0.00	0.00	0.00	0.00	0.00	0.00	0.00
NON-CAPITAL OBJECTS	0.00	0.00	0.00	0.00	0.00	0.00	0.00	0.00
SPECIAL CURRICULUM	0.00	0.00	0.00	0.00	0.00	0.00	0.00	0.00
160000	CO-CURRICULAR							
SALARIES	123,491.00	69,525.51	56.30	123,496.00	56,513.13	45.76	0.00	66,982.87
EMPLOYEE BENEFITS	16,292.00	8,374.91	51.41	18,941.00	6,717.73	35.47	0.00	12,223.27
PURCHASED SERVICES	33,370.00	17,631.58	52.84	36,790.00	12,983.88	35.29	12,520.53	11,285.59
NON-CAPITAL OBJECTS	23,115.00	11,932.43	51.62	28,202.00	22,350.99	79.25	12,514.68	-6,663.67
CAPITAL OBJECTS	0.00	0.00	0.00	0.00	0.00	0.00	0.00	0.00
OTHER OBJECTS	14,095.00	5,559.00	39.44	15,395.00	7,297.73	47.40	7,440.97	656.30
CO-CURRICULAR	210,363.00	113,023.43	53.73	222,824.00	105,863.46	47.51	32,476.18	84,484.36
170000	SPECIAL NEEDS							
SALARIES	71,296.00	14,966.61	20.99	154,820.00	56,351.21	36.40	0.00	98,468.79
EMPLOYEE BENEFITS	65,378.00	9,841.91	15.05	124,390.00	32,048.09	25.76	0.00	92,341.91
PURCHASED SERVICES	0.00	9.42	0.00	15.00	0.00	0.00	0.00	15.00
NON-CAPITAL OBJECTS	1,500.00	766.25	51.08	3,943.00	392.23	9.95	1,200.00	2,350.77
CAPITAL OBJECTS	0.00	0.00	0.00	0.00	0.00	0.00	0.00	0.00
OTHER OBJECTS	1,500.00	1,040.00	69.33	2,000.00	1,120.00	56.00	1,200.00	-320.00
SPECIAL NEEDS	139,674.00	26,624.19	19.06	285,168.00	89,911.53	31.53	2,400.00	192,856.47
INSTRUCTION	4,986,720.00	1,890,512.95	37.91	5,125,773.00	1,743,844.54	34.02	95,436.93	3,286,491.53

Obj	2016-17		2016-17		2017-18		Encumbered Amount	Unencumbered Balance
	Original Budget	FYTD Activity	FYTD %	Budget	FYTD Activity	FYTD %		
200000	SUPPORT SERVICES							
210000	PUPIL SERVICES							
SALARIES	147,984.00	59,373.57	40.12	156,335.00	56,002.76	35.82	0.00	100,332.24
EMPLOYEE BENEFITS	82,667.00	33,974.74	41.10	87,884.00	25,130.00	28.59	0.00	62,754.00
PURCHASED SERVICES	7,635.00	3,192.11	41.81	9,323.00	4,373.21	46.91	4,882.35	67.44
NON-CAPITAL OBJECTS	5,330.00	1,606.79	30.15	3,295.00	3,134.40	95.13	1,745.00	-1,584.40
CAPITAL OBJECTS	0.00	0.00	0.00	0.00	0.00	0.00	0.00	0.00
OTHER OBJECTS	210.00	210.00	100.00	140.00	0.00	0.00	190.00	-50.00
PUPIL SERVICES	243,826.00	98,357.21	40.34	256,977.00	88,640.37	34.49	6,817.35	161,519.28
220000	INSTRUCTIONAL STAFF SERVICES							
SALARIES	191,928.00	70,589.18	36.78	194,984.00	62,919.44	32.27	0.00	132,064.56
EMPLOYEE BENEFITS	131,388.00	37,909.32	28.85	113,674.00	31,883.02	28.05	0.00	81,790.98
PURCHASED SERVICES	59,557.00	31,914.85	53.59	45,692.00	21,245.54	46.50	6,755.15	17,691.31
NON-CAPITAL OBJECTS	57,666.00	25,956.51	45.01	57,844.00	26,434.16	45.70	29,033.59	2,376.25
CAPITAL OBJECTS	0.00	0.00	0.00	0.00	0.00	0.00	0.00	0.00
OTHER OBJECTS	1,355.00	302.00	22.29	1,063.00	482.00	45.34	163.00	418.00
INSTRUCTIONAL STAFF SERVI	441,894.00	166,671.86	37.72	413,257.00	142,964.16	34.59	35,951.74	234,341.10
230000	GENERAL ADMINISTRATION							
SALARIES	140,183.00	70,335.10	50.17	141,000.00	63,678.84	45.16	0.00	77,321.16
EMPLOYEE BENEFITS	57,749.00	24,589.25	42.58	53,359.00	20,903.13	39.17	0.00	32,455.87
PURCHASED SERVICES	56,937.00	26,901.54	47.25	55,840.00	24,214.75	43.36	0.00	31,625.25
NON-CAPITAL OBJECTS	9,398.00	2,370.36	25.22	9,698.00	2,344.40	24.17	0.00	7,353.60
CAPITAL OBJECTS	0.00	0.00	0.00	0.00	0.00	0.00	0.00	0.00
OTHER OBJECTS	10,800.00	10,062.66	93.17	8,500.00	6,425.96	75.60	0.00	2,074.04
GENERAL ADMINISTRATION	275,067.00	134,258.91	48.81	268,397.00	117,567.08	43.80	0.00	150,829.92
240000	BUILDING ADMINISTRATION							
SALARIES	352,159.00	171,876.04	48.81	361,390.00	156,748.79	43.37	0.00	204,641.21
EMPLOYEE BENEFITS	209,672.00	83,867.82	40.00	202,515.00	74,565.77	36.82	0.00	127,949.23
PURCHASED SERVICES	2,600.00	1,000.00	38.46	0.00	0.00	0.00	600.00	-600.00
NON-CAPITAL OBJECTS	8,210.00	1,102.28	13.43	7,310.00	1,928.60	26.38	7,132.00	-1,750.60

Obj	2016-17		2016-17		2017-18		Encumbered Amount	Unencumbered Balance
	Original Budget	FYTD Activity	FYTD %	Budget	FYTD Activity	FYTD %		
200000	SUPPORT SERVICES							
240000	BUILDING ADMINISTRATION							
CAPITAL OBJECTS	0.00	0.00	0.00	0.00	0.00	0.00	0.00	0.00
OTHER OBJECTS	1,030.00	0.00	0.00	1,265.00	0.00	0.00	1,265.00	0.00
BUILDING ADMINISTRATION	573,671.00	257,846.14	44.95	572,480.00	233,243.16	40.74	8,997.00	330,239.84
250000	BUSINESS ADMINISTRATION							
SALARIES	416,000.00	200,859.09	48.28	444,395.00	204,438.88	46.00	0.00	239,956.12
EMPLOYEE BENEFITS	210,845.00	108,173.16	51.30	280,636.00	95,048.19	33.87	0.00	185,587.81
PURCHASED SERVICES	1,058,211.00	506,583.36	47.87	1,066,333.00	405,398.53	38.02	4,997.00	655,937.47
NON-CAPITAL OBJECTS	109,940.00	72,970.72	66.37	113,244.00	71,089.07	62.78	0.00	42,154.93
CAPITAL OBJECTS	5,000.00	0.00	0.00	0.00	0.00	0.00	0.00	0.00
INSURANCE & JUDGMENTS	0.00	0.00	0.00	0.00	0.00	0.00	0.00	0.00
OTHER OBJECTS	1,500.00	477.98	31.87	1,500.00	410.00	27.33	0.00	1,090.00
BUSINESS ADMINISTRATION	1,801,496.00	889,064.31	49.35	1,906,108.00	776,384.67	40.73	4,997.00	1,124,726.33
260000	CENTRAL SERVICES							
SALARIES	72,670.00	37,910.91	52.17	17,650.00	5,339.23	30.25	0.00	12,310.77
EMPLOYEE BENEFITS	24,430.00	12,266.71	50.21	18,953.00	2,885.16	15.22	0.00	16,067.84
PURCHASED SERVICES	151,791.00	47,345.43	31.19	212,500.00	72,452.40	34.10	0.00	140,047.60
NON-CAPITAL OBJECTS	114,295.00	76,789.50	67.19	117,050.00	74,983.65	64.06	191.50	41,874.85
CAPITAL OBJECTS	19,500.00	1,012.00	5.19	16,000.00	598.25	3.74	0.00	15,401.75
OTHER OBJECTS	0.00	0.00	0.00	0.00	0.00	0.00	0.00	0.00
CENTRAL SERVICES	382,686.00	175,324.55	45.81	382,153.00	156,258.69	40.89	191.50	225,702.81
270000	INSURANCE							
INSURANCE & JUDGMENTS	122,144.00	115,444.00	94.51	138,506.00	120,035.00	86.66	0.00	18,471.00
INSURANCE	122,144.00	115,444.00	94.51	138,506.00	120,035.00	86.66	0.00	18,471.00

Obj	2016-17		2016-17		2017-18		Encumbered Amount	Unencumbered Balance
	Original Budget	FYTD Activity	FYTD %	Budget	FYTD Activity	FYTD %		
200000	SUPPORT SERVICES							
280000	DEBT SERVICE							
DEBT RETIREMENT	0.00	0.00	0.00	0.00	0.00	0.00	0.00	0.00
DEBT SERVICE	0.00	0.00	0.00	0.00	0.00	0.00	0.00	0.00
290000	OTHER SUPPORT SERVICES							
SALARIES	0.00	0.00	0.00	0.00	0.00	0.00	0.00	0.00
EMPLOYEE BENEFITS	140,000.00	136,665.35	97.62	175,000.00	167,153.64	95.52	0.00	7,846.36
PURCHASED SERVICES	2,800.00	1,312.18	46.86	2,593.00	547.00	21.10	0.00	2,046.00
OTHER SUPPORT SERVICES	142,800.00	137,977.53	96.62	177,593.00	167,700.64	94.43	0.00	9,892.36
SUPPORT SERVICES	3,983,584.00	1,974,944.51	49.58	4,115,471.00	1,802,793.77	43.81	56,954.59	2,255,722.64
400000	NON-PROGRAM TRANSACTIONS							
410000	INTERFUND OPERATING TRANSFERS							
OPERATING TRANSFERS-OUT	1,196,874.00	0.00	0.00	1,125,767.00	5,748.30	0.51	0.00	1,120,018.70
INTERFUND OPERATING TRANS	1,196,874.00	0.00	0.00	1,125,767.00	5,748.30	0.51	0.00	1,120,018.70
430000	GEN. TUITION PAYMENTS							
PURCHASED SERVICES	942,753.00	30,725.57	3.26	1,080,954.00	4,094.00	0.38	0.00	1,076,860.00
NON-CAPITAL OBJECTS	0.00	0.00	0.00	0.00	0.00	0.00	0.00	0.00
OTHER OBJECTS	0.00	0.00	0.00	0.00	0.00	0.00	0.00	0.00
GEN. TUITION PAYMENTS	942,753.00	30,725.57	3.26	1,080,954.00	4,094.00	0.38	0.00	1,076,860.00
490000	NON-PROGRAM TRANSACTIONS							
OTHER OBJECTS	0.00	0.00	0.00	0.00	1,225.13	0.00	0.00	-1,225.13
NON-PROGRAM TRANSACTIONS	0.00	0.00	0.00	0.00	1,225.13	0.00	0.00	-1,225.13
NON-PROGRAM TRANSACTIONS	2,139,627.00	30,725.57	1.44	2,206,721.00	11,067.43	0.50	0.00	2,195,653.57

<u>Obj</u>	<u>2016-17</u> <u>Original Budget</u>	<u>2016-17</u> <u>FYTD Activity</u>	<u>2016-17</u> <u>FYTD %</u>	<u>2017-18</u> <u>Budget</u>	<u>2017-18</u> <u>FYTD Activity</u>	<u>2017-18</u> <u>FYTD %</u>	<u>Encumbered</u> <u>Amount</u>	<u>Unencumbered</u> <u>Balance</u>
Grand Expense Totals	11,109,931.00	3,896,183.03	35.07	11,447,965.00	3,557,705.74	31.08	152,391.52	7,737,867.74

Number of Accounts: 3441

***** End of report *****

**SCHOOL DISTRICT OF COLBY
COLBY, WISCONSIN**

**REQUIRED AUDIT COMMUNICATIONS
TO THE BOARD OF EDUCATION**

Year Ended June 30, 2017

**Johnson Block & Company, Inc.
Certified Public Accountants
1315 Bad Axe Court; P.O. Box 271
Viroqua, Wisconsin 54665
(608) 637-2082
Fax: (608) 637-3021**

**SCHOOL DISTRICT OF COLBY
COLBY, WISCONSIN**

Year Ended June 30, 2017

Index

	<u>Page</u>
Audit Matters Requiring Communication to the Governing Body.....	1 - 3
Management Letter.....	4
Explanation of Adjusting Journal Entries and Passed Journal Entries	5 - 6
Additional Comments.....	7
Concluding Remarks	8
Appendix	
Adjusting Journal Entries	
Passed (Proposed) Journal Entry	



Certified Public Accountants

1315 Bad Axe Court • P.O. Box 271 • Viroqua, Wisconsin 54665 • TEL 608-637-2082 • FAX 608-637-3021

**AUDIT MATTERS REQUIRING COMMUNICATION
TO THE GOVERNING BODY**

To the Board of Education
School District of Colby
Colby, Wisconsin

We have audited the financial statements of the governmental activities, each major fund, and the aggregate remaining fund information of the School District of Colby (District) for the year ended June 30, 2017. Professional standards require that we provide you with information about our responsibilities under generally accepted auditing standards, *Government Auditing Standards*, the Uniform Guidance, and State Single Audit Guidelines, as well as certain information related to the planned scope and timing of our audit. We have communicated such information in our letter to you dated March 6, 2017. Professional standards also require that we communicate to you the following information related to our audit.

Significant Audit Findings

Qualitative Aspects of Accounting Practices

Management is responsible for the selection and use of appropriate accounting policies. The significant accounting policies used by the District are described Note 1 to the financial statements. No new accounting policies were adopted and the application of existing policies was not changed during the year ended June 30, 2017. We noted no transactions entered into by the District during the year for which there is a lack of authoritative guidance or consensus. All significant transactions have been recognized in the financial statements in the proper period.

Accounting estimates are an integral part of the financial statements prepared by management and are based on management's knowledge and experience about past and current events and assumptions about future events. Certain accounting estimates are particularly sensitive because of their significance to the financial statements and because of the possibility that future events affecting them may differ significantly from those expected. The most sensitive estimates affecting the financial statements relate to estimating other post-employment benefits, pension liability, compensated absences, depreciable lives, and depreciating fixed assets.

We evaluated the key factors and assumptions used to develop the estimates in determining that they are reasonable in relation to the financial statements taken as a whole.

The financial statement disclosures are neutral, consistent, and clear.



Difficulties Encountered in Performing the Audit

We encountered no significant difficulties in dealing with management in performing and completing our audit.

Corrected and Uncorrected Misstatements

Professional standards require us to accumulate all known and likely misstatements identified during the audit, other than those that are clearly trivial, and communicate them to the appropriate level of management. The attached schedule summarizes uncorrected misstatements of the financial statements. Management has determined that their effects are immaterial, both individually and in the aggregate, to the financial statements taken as a whole. Also attached are misstatements detected as a result of audit procedures that were corrected by management.

Disagreements with Management

For purposes of this letter, a disagreement with management is a financial accounting, reporting, or auditing matter, whether or not resolved to our satisfaction, that could be significant to the financial statements or the auditor's report. We are pleased to report that no such disagreements arose during the course of our audit.

Management Representations

We have requested certain representations from management that are included in the management representation letter dated November 20, 2017.

Management Consultations with Other Independent Accountants

In some cases, management may decide to consult with other accountants about auditing and accounting matters, similar to obtaining a "second opinion" on certain situations. If a consultation involves application of an accounting principle to the District's financial statements or a determination of the type of auditor's opinion that may be expressed on those statements, our professional standards require the consulting accountant to check with us to determine that the consultant has all the relevant facts. To our knowledge, there were no such consultations with other accountants.

Other Audit Findings or Issues

We generally discuss a variety of matters, including the application of accounting principles and auditing standards, with management each year prior to retention as the District's auditors. However, these discussions occurred in the normal course of our professional relationship and our responses were not a condition to our retention.



Other Matters

We applied certain limited procedures to the Schedule of Funding Progress for Post-Employment Benefit Plans, Wisconsin Retirement System schedules, and budgetary comparison information, which is required supplementary information (RSI) that supplements the basic financial statements. Our procedures consisted of inquiries of management regarding the methods of preparing the information and comparing the information for consistency with management's responses to our inquiries, the basic financial statements, and other knowledge we obtained during our audit of the basic financial statements. We did not audit the RSI and do not express an opinion or provide any assurance on the RSI.

We were engaged to report on combining and individual fund financial statements and schedules of awards, which accompanies the financial statements but are not RSI. With respect to this supplementary information, we made certain inquiries of management and evaluated the form, content, and methods of preparing the information to determine that the information complies with accounting principles generally accepted in the United States of America, the method of preparing it has not changed from the prior period, and the information is appropriate and complete in relation to our audit of the financial statements. We compared and reconciled the supplementary information to the underlying accounting records used to prepare the financial statements or the financial statements themselves.

Other Information Regarding Nonattest Services We Performed

We have not performed any advisory or nonattest services that would impair our independence as your auditor. Management has overseen, directed and accepted all nonattest services that were provided.

Restriction on Use

This information is intended solely for the information and use of the Board of Education and management of the School District of Colby, and is not intended to be, and should not be, used by anyone other than these specified parties.

Johnson Block & Company, Inc.

Johnson Block & Company, Inc.
Certified Public Accountants
Viroqua, Wisconsin
November 20, 2017



Certified Public Accountants

1315 Bad Axe Court • P.O. Box 271 • Viroqua, Wisconsin 54665 • TEL 608-637-2082 • FAX 608-637-3021

MANAGEMENT LETTER

To the Board of Education
School District of Colby
Colby, Wisconsin

In planning and performing our audit of the financial statements of the School District of Colby for the year ended June 30, 2017, we considered the District's internal control in order to determine our auditing procedures for the purpose of expressing an opinion on the financial statements and not to provide assurance on internal control.

However, during our audit we became aware of other matters that are opportunities for strengthening internal controls and operating efficiency. The following pages that accompany this letter summarize our comments and suggestions regarding those matters. This letter does not affect our report dated November 20, 2017, on the financial statements of the School District of Colby.

We would like to take this opportunity to acknowledge the many courtesies extended to us by the District's personnel during the course of our work. In particular, we would like to note the considerable assistance and cooperation provided to us by Steve Kolden, Audra Brooks and the staff.

We shall be pleased to discuss any of the matters referred to in this letter. Should you desire assistance in implementing any of the following suggestions, we would welcome the opportunity of assisting you in these matters.

Johnson Block & Company, Inc.

Johnson Block & Company, Inc.
Certified Public Accountants
Viroqua, Wisconsin
November 20, 2017

SCHOOL DISTRICT OF COLBY
COLBY, WISCONSIN
Year Ended June 30, 2017

ADJUSTING JOURNAL ENTRIES

We are frequently requested by our clients to discuss the overall condition of their accounting records and what our role is as your audit firm. We believe that these matters should be discussed at each audit. The following section describes your accounting process in general terms and the ways in which we work with your staff.

The District processes accounting transactions based on the type of transaction involved. Money coming in is processed using a cash receipt system. The payment of bills is done through an accounts payable system. Employees' salaries are paid using a payroll system. These three systems are responsible for recording and summarizing the vast majority of your financial transactions.

Beyond the three systems described in the preceding paragraph, another system is used to make corrections and to record non-cash transactions. This system involves preparing general journal entries. Journal entries provide the ability to make changes to the financial data entered in the other systems. As your auditor, our role is to substantiate year end financial balances and information presented by your accounting personnel, and compare it to supporting information and outside confirmations. When information in your records does not agree with audit evidence, an adjusting entry is necessary to correct your records. Sometimes these entries are identified by your staff as they get ready for the audit. Other adjustments are prepared by us as we discover that your general ledger balances need to be changed to reflect the correct balances.

For the June 30, 2017 audit, we proposed adjustments and reclassifications to your records. The effect of these journal entries is not considered to be material to the financial statements of the School District of Colby. The proposed entries were accepted by the District's management. All of these changes are reflected properly in your audited financial statements.

Because we are providing assistance to your staff by proposing changes to correct your financial information, you should be aware of these processes. Many of our clients rely on us to make year end adjustments as we have described. In many cases, we have the experience or expertise to compute, and identify, corrections to your records. We work with many clients on similar issues, so it may be more efficient for you to have us do some of the one-time adjustments, rather than your staff spending hours researching the proper adjustment.

Due to the technical nature of financial reporting and complying with financial reporting standards, most clients have their CPA firm prepare the year end financial statements and note disclosures. We have provided these services to your District.

We are communicating this information to you to give you a better understanding of what we do and how the year end process works. Our job as auditors is to bring in an outside perspective and provide a level of comfort that your financial reporting system is materially correct and accurately reflects the financial activity for the year. However, in many cases, our services go beyond auditing. Our experience and training can provide a very cost-effective means of providing the year end accounting assistance that you need.

We hope that by providing this information on what we do, you will have a better understanding of our role, and the various ways that we work with your staff.

PASSED JOURNAL ENTRIES

Passed journal entries may occur due to transaction timing, industry practices or lack of overall significance. There was one potential (passed) journal entry identified in our audit that was not posted to the general ledger.

ADDITIONAL COMMENTS

To comply with our professional standards, deficiencies in internal control have been communicated to you in the Schedule of Findings and Questioned Costs in the bound financial statements with independent auditor's reports.

OTHER INTERNAL CONTROL MATTERS

Athletic Event Admissions

Currently all admission fees for athletic events are being collected, retained, and disbursed by the Booster Club. This procedure may be in conflict with DPI requirements. According to the Wisconsin Uniform Financial Accounting Requirements (WUFAR), athletic admission fees are to be recorded in the General Fund using revenue source code 271. Therefore, we recommend the District consult with the DPI Financial Staff to consider reviewing the procedures on depositing athletic admission fees and the disbursement of these funds, to ensure the proper reporting in the District's general ledger accounting software.

Sales Tax

During the audit, we noted that the District paid sales tax on a number of purchases made with the District credit card. We recommend that all credit card transactions be reviewed by District staff to ensure that sales tax is not paid in error.

Credit Card Receipts

During the audit, we noted several purchases made with the District credit card for which the District did not have a receipt or other supporting documentation. We recommend that the District require supporting documentation for all purchases made with the District credit card before approving payment of the monthly bill.

CONCLUDING REMARKS

We would like to thank you for allowing us to serve you. We are committed to assisting you in the long-term financial success of the School District of Colby and our comments are intended to draw to your attention issues which need to be addressed by the District to meet its goals and responsibilities.

The comments and suggestions in this communication are not intended to reflect in any way on the integrity or ability of the personnel of the District. They are made solely in the interest of establishing sound internal control practices required by changing professional standards. The District's staff is deeply committed to maintaining the financial reporting system so that informed decisions can be made. They were receptive to our comments and suggestions.

We will review the status of these comments during each audit engagement.

If you have any questions or comments regarding this communication or the financial statements, do not hesitate to contact us.

Client: **Colby SD - Colby School District**
 Engagement: **COLBY SD - 2017 Colby School District**
 Period Ending: **6/30/2017**
 Trial Balance: **TB**
 Workpaper: **Adjusting Journal Entries Report**

Account	Description	Debit	Credit
Adjusting Journal Entries JE # 1000			
To reclass IDEA preschool revenue			
27 R 800 730 150000 341	SPECIAL EDUC./SPECIAL CURRICULUM/SPECIAL PROJECT GRANT	7,559.97	
27 R 800 730 150000 347	SPECIAL PROJECT GRANT		7,559.97
Total		<u>7,559.97</u>	<u>7,559.97</u>
Adjusting Journal Entries JE # 1001			
To record \$100 sale of old district office building as revenue			
10 E 800 310 231500 000	GENERAL FUND/BOARD OF ED. LEGAL/PERSONAL SERVICES	100.00	
10 R 800 862 500000 000	LAND AND OTHER REAL PROP SALES		100.00
Total		<u>100.00</u>	<u>100.00</u>

Client: **Colby SD - Colby School District**
 Engagement: **COLBY SD - 2017 Colby School District**
 Period Ending: **6/30/2017**
 Trial Balance: **TB**
 Workpaper: **Proposed JE Report**

Account	Description	Debit	Credit
Proposed JE # 100			
To adjust health insurance liability			
27 E 050 241 152000 011	SPECIAL EDUC./EARLY CHILDHOOD/MEDICAL	9,060.92	
27 L 000 000 811631 000	SPECIAL EDUC./HEALTH INSURANCE		9,060.92
Total		<u>9,060.92</u>	<u>9,060.92</u>

COLBY SCHOOL DISTRICT ACADEMIC AND CAREER PLANNING

Information about what ACP is and why Wisconsin Administrative Rule PI26 requires it, and a summary of how the school district will meet those requirements.

Education for Employment was established in 1985 in response to the growing concern over the number of youth who failed to make a successful transition from school to postsecondary endeavors. s. 121.02 (1)(m), Wis. Stats., states that every school board shall provide access to an Education for Employment program. Chapter PI 26, the administrative rule for this program, was revised and became effective on July 1, 2004. On June 30, 2013, Wisconsin Statute 115.28(59) was signed to require implementation of academic and career planning (ACP) statewide beginning in 2017-18 for pupils enrolled in grades 6 to 12 in a school district. It was determined that rather than creating a new rule addressing ACP, the current PI26 would be updated and revised to include the required ACP components.

Chapter PI 26

Education for Employment Plans and Programs

PI 26.01 Applicability and purpose.

(1) Under s. 121.02 (1) (m), Stats., every school board shall provide access to an education for employment program approved by the state superintendent. Under s. 115.28 (59), Stats., the state superintendent shall ensure that every school board is providing academic and career planning services to pupils enrolled in grades 6 to 12 in the school district beginning in the 2017-18 school year.

(2) This chapter establishes the requirements for education for employment programs. The purpose of education for employment programs is to do all of the following:

- (a)** Prepare elementary and secondary pupils for future employment.
- (b)** Ensure technological literacy; to promote lifelong learning.
- (c)** Promote good citizenship.
- (d)** Promote cooperation among business, industry, labor, postsecondary schools, and public schools.
- (e)** Establish a role for public schools in the economic development of Wisconsin.

(3) The purpose of academic and career planning services is to assist pupils with planning and preparing for opportunities after graduating from high school. These opportunities may include postsecondary education and training that leads to careers. This chapter describes school districts' academic and career planning responsibilities while allowing school districts to determine how they meet those responsibilities.

The ACP Committee

The ACP Committee will be comprised of but not be limited to the following:

- MS & HS Counselors
- MS & HS Principals
- Special Education Teacher
- 2 High School Teachers
- 2 Middle School Teachers
- CTE Staff

Community Involvement in ACP

It is important to continue to connect with other providers outside of school to ensure access to expertise and services that cannot be provided by the school alone. Staff and community members will work to continually collaborate and plan for the best opportunities for our students.

An analysis of local, regional, and state labor market

Colby School District is located in Clark and Marathon Counties. The Workforce and Economic Profile for both Marathon and Clark County will be displayed on the district webpage for viewing. The webpage will also include a link to the Bureau of Labor Statistics for the ability to search information in areas outside Marathon and Clark County.

Career and Technical Education program provided in the school district.

A description of all Career and Technical Education programs will be included in the Colby Student Course Description Handbook. The handbook is to be updated yearly by the High School counselor and displayed on the district webpage. Physical copies of the handbook are distributed to all 8th grade students at freshman orientation as well as available in the counselor's office for all students to view.

A detailed 6-12 ACP instructional scope and sequence that will meet ACP requirements.

Beginning in 2017 all 6-12 students are required to complete an ongoing portfolio documenting all their ACP achievements. Individual student's portfolio may differ from other students depending on that student's ACP goals, experiences and achievements.

A detailed instructional scope and sequence will be displayed on the ACP website for students, parent's community and students. ACP is an ongoing and evolving plan that may undergo revisions by the Colby ACP committee and/or School Board.

Each student will be personally responsible for developing, adjusting and completing their academic and career plan. Student ownership assures that career options and activities align with interests and abilities. Coaching, encouraging and constructive critique are expected from parents, teachers and mentors.

A summary of the professional development provided to staff to implement ACP.

Plan Professional Development In order to assist staff in delivering ACP services, the following practices are/will be employed:

- NTC Dual Credit instructors receive ongoing professional development through the college
- Colby ACP Committee provides opportunities for staff enrichment in ACP processes
- Frequent reflections and check-points are built into the ACP process to allow for ACP implementation with fidelity
- Ongoing documentation of ACP classroom activities monitored by the Colby ACP Committee.
- Colby ACP Committee consults frequently with staff in regard to completing, updating and modifying ACP classroom activities

A plan for involving parents on a regular basis.

ACP is intended to equip students and their families with the tools necessary to make more informed choices about post-secondary education and training as it leads to careers.

- Counselors available by appointment to discuss ACP progress and goals.
- Open House and registration events
- District website, social media
- District newsletter
- ACP parent communication
- Career Cruising access for all students grades 6-12,
- Parent access to Career Cruising.
- Freshman Orientation with 8th graders & parents
- Academic grades are available in Infinite Campus
- Parent/Teacher conferences twice a year. Discussion of career goals is encouraged.
- Financial Aid Night

Colby School District ACP Goals

ALL students will graduate “College and Career Ready” possessing the following skills and attributes;

- Understand how their own unique strengths and interests align with future opportunities for employment, of post-secondary education.
- Prepare and maintain a personal plan for goal attainment that is flexible and meets their individual needs.
- Develop an understanding of problem solving and how to apply problem solving to a variety of educational and work environments.
- Effectively navigate post-secondary goals and transitions into adulthood.

Support Systems-Throughout high school, each student will have developed a network of people (teachers, advisors, counselors, mentors, parents) that he/she can call upon through the next steps on his/her career path.

Career Planning Goal- Upon graduation, each student will have a post-secondary plan for next steps in their career path, whether it is more training or schooling, and gaining more specific work experience, whatever moves closer to reaching their career aspirations.

SITE PARKING RE-CAP

EXISTING AND PROPOSED PARKING LOT STALL COUNT

EXISTING PARKING LOT
259 EXISTING PARKING STALLS

PROPOSED PARKING LOT
300 PROPOSED PARKING STALLS
*RESULTING IN A NET INCREASE OF 41 STALLS

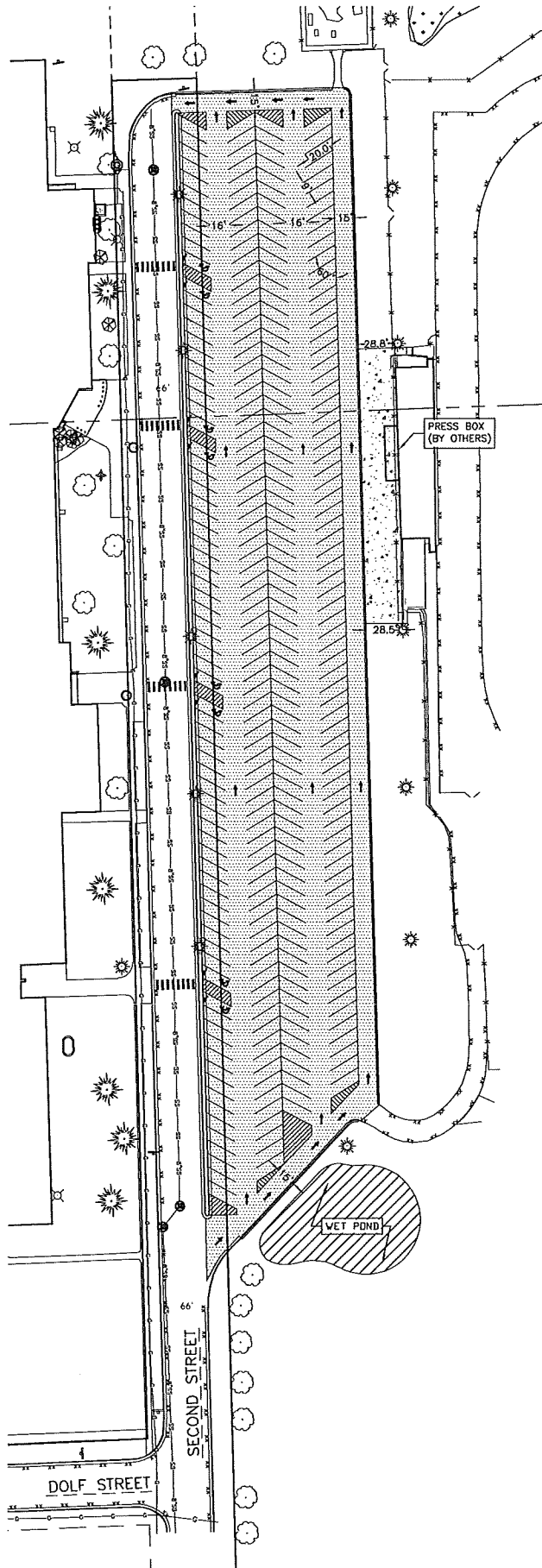

Graphic Scale:

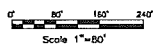

CONCEPT PLAN 1

Project Title: **COLBY SCHOOL DISTRICT
HIGH SCHOOL PARKING LOT IMPROVEMENTS**

Project Location: 700 N 2ND STREET COLBY, WI 5441



ARCHITECTURE
ENGINEERING
INTERIOR DESIGN



SITE PARKING RE-CAP

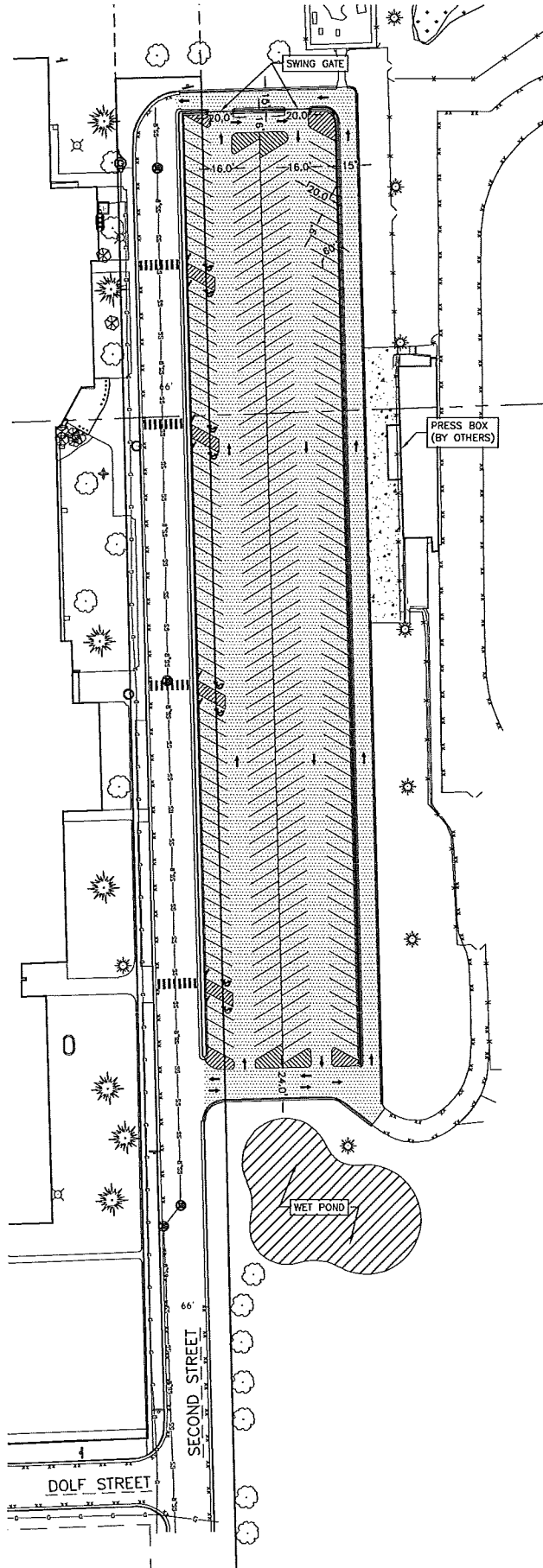

EXISTING AND PROPOSED PARKING LOT STALL COUNT	
EXISTING PARKING LOT	
259 EXISTING PARKING STALLS	
PROPOSED PARKING LOT	
267 PROPOSED PARKING STALLS	
*RESULTING IN A NET INCREASE OF 8 STALLS	

Graphic Scale:

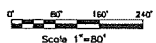

CONCEPT PLAN 2

Project Title: **COLBY SCHOOL DISTRICT
HIGH SCHOOL PARKING LOT IMPROVEMENTS**
Project Location: 200 N 2ND STREET COLBY, WI 54601



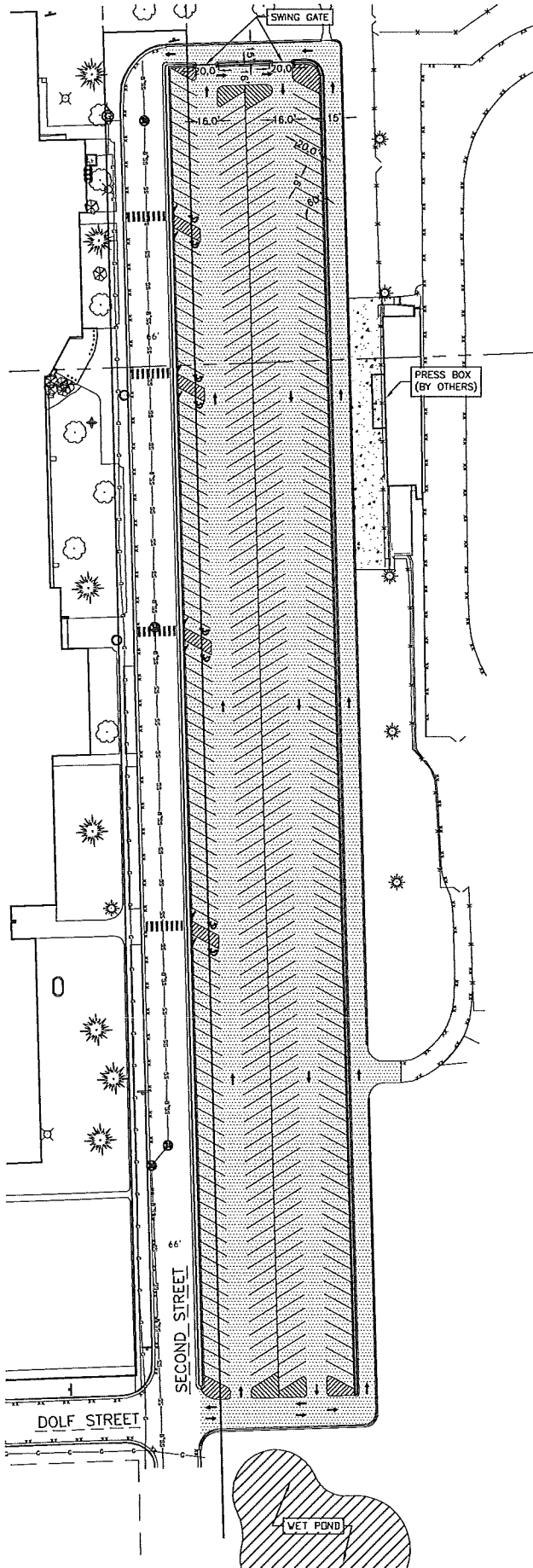

SITE PARKING RE-CAP

EXISTING AND PROPOSED PARKING LOT STALL COUNT

EXISTING PARKING LOT
259 EXISTING PARKING STALLS

PROPOSED PARKING LOT
383 PROPOSED PARKING STALLS
*RESULTING IN A NET INCREASE OF 124 STALLS

ADDITIONAL PARKING OPTION
EXTEND PARKING HALF WAY TO DOLF STREET
355 PROPOSED PARKING STALLS (INCREASE OF 96 STALLS)

Graphic Scale:

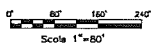

CONCEPT PLAN 3

Project Title: **COLBY SCHOOL DISTRICT
HIGH SCHOOL PARKING LOT IMPROVEMENTS**

Project Location: 701 N 2ND STREET COLBY, WI 54601



ARCHITECTURE
ENGINEERING
INTERIOR DESIGN



Middle School Roof

Direction for Bid Documents

Decision on TYPE of roof / Roof Design

- **Ballasted** – secured on sides and held in place with rock
- **Fully Adhered** – Roofing material is directly adhered to insulation

Decision on Insulation

Added 2" – Current plan is to add 2 inches to increase insulation and energy efficiencies for the building and heating.

- **Completely Replace ALL Current Insulation** – Removes current insulation and replaces with new. New insulation materials are more efficient and also increase energy efficiencies.
- **Replace only poor / deteriorated Insulation** – Removes only the sub layers that are bad and water damaged. Will not know how extensive this damage is until we remove the current ballasted roof.

CO-CURRICULAR

FBLA Head Advisor	7	\$714.00
FBLA Assistant Advisor	6	\$612.00
FCCLA Advisor	7	\$714.00
FFA Advisor	8	\$816.00
Assistant FFA Advisor	6	\$612.00
Newspaper Advisor	10	\$1,020.00
Pep Band Instructor	10	\$1,020.00
Show Choir Advisor	10	\$1,020.00
Skills USA Advisor	7	\$714.00
Skills USA Ass't	6	\$612.00

EXTRA-CURRICULAR

Annual Advisor	13	\$1,326.00
Annual Assistant Advisor	6	\$612.00
Cheerleading/Pom	5	\$510.00
Pom/Dance Advisor - per season		
Chess Team Advisor *	5	\$510.00
Drama Advisor	13	\$1,326.00
Assistant Drama Advisor	10	\$1,020.00
Musical Instrumental Director	5	\$510.00
Musical Vocal Director	5	\$510.00
Foreign Language Advisor	7	\$714.00
Forensics Advisor	11	\$1,122.00
Forensics Assistant Advisor	5	\$510.00
Madrigal Director	5	\$510.00
Math Team Advisor *	5	\$510.00
NHS Advisor - HS	5	\$510.00
NHS Advisor - MS	3	\$306.00
Prom Head	3	\$306.00
SADD Advisor	5	\$510.00
Special Olympics - Head Coach - per season	5	\$510.00
Special Olympics - Ass't Coach - per season	3	\$306.00
Student Advisor - Academic Competition *	5	\$510.00
Student Council Advisor - HS	8	\$816.00
Student Council Advisor - MS	3	\$306.00
Water Ballet Head	8	\$816.00
Water Ballet Assistant	3	\$306.00

SECTION 1. POST-EMPLOYMENT BENEFITS

8.01 Voluntary Early Retirement Benefit Program

A. Eligibility

Teachers will be eligible for the early retirement benefit provided for in this Article if they a) declare, in writing, to the Board of Education, their retirement intentions prior to February 1 of the calendar year in which they intend to retire from an employer contributing to the Wisconsin Retirement System, b) are WRS eligible for retirement and c) were hired prior to July 1, 2013.

B. Application and Limitation

Application for participation in the early retirement benefit provided for in this Article must be made by the teacher in writing and submitted to the School Board on or before February 1st of the last school year prior to retirement from an employer contributing to the Wisconsin Retirement System. No more than three (3) teachers shall be eligible to begin participation in the early retirement benefits provided for in this Article in the same year unless the School Board, at its sole discretion, approves a higher number. In the event there are more applicants than are eligible to participate, the most senior applicants, based on Colby School District experience, will be selected. If seniority is equal, the selection will be based on the order of receipt of the application.

C. Early Retirement Benefit Health Insurance

For Staff hired prior to July 1, 1986

Upon retirement, for an eligible teacher whose application has been approved, the District will credit up to three thousand dollars for each year of service (\$3,000 x years of service at the Colby School District) for the retiree for a premium only health reimbursement account (HRA) until the teacher becomes entitled to Medicare.

- 1) Each qualifying teacher shall have \$3,000, or such amount as proportional to the employment status of the teacher pursuant to his/her letter of appointment, designated in an HRA (Health Retirement Account) to be used for insurance premiums upon retirement.
- 2) In the event of death of the retiree, his or her spouse will be eligible to the above credits on the above basis as if the retiree was still living through the eligibility period reflected in this benefit offering had the employee survived.
- 3) There is no cash equivalency benefit available under this provision for the retiree or any surviving spouse.

For Staff hired after July 1, 1986, yet prior to July 1, 1992

Upon retirement, for an eligible teacher whose application has been approved, the District will credit up to three thousand dollars for each year of service (\$3,000 x years of service at the Colby School District, up to a maximum of \$100,000) for the retiree for a premium only health reimbursement account (HRA) until the teacher becomes entitled to Medicare.

- 1) Each qualifying teacher shall have \$3,000, or such amount as proportional to the employment status of the teacher pursuant to his/her letter of appointment, designated in an HRA (Health Retirement Account) to be used for health insurance premiums upon retirement. The HRA may be funded or unfunded as determined by the District unless otherwise required by law.
- 2) In the event of death of the retiree, his or her spouse will be eligible to the above credits on the above basis as if the retiree was still living through the eligibility period reflected in this benefit offering had the employee survived.
- 3) There is no cash equivalency benefit available under this provision for the retiree or any surviving spouse.

For Staff hired after July 1, 1992, yet prior to July 1, 2004.

Upon retirement, for an eligible teacher whose application has been approved, the District will credit up to three thousand dollars for each year of service (\$3,000 x years of service at the Colby School District, up to a maximum of \$75,000) for the retiree for a premium only health reimbursement account (HRA) until the teacher becomes entitled to Medicare.

- 1) Each qualifying teacher shall have \$3,000, or such amount as proportional to the employment status of the teacher pursuant to his/her letter of appointment, designated in an HRA (Health Retirement Account) to be used for health insurance

premiums upon retirement. The HRA may be funded or unfunded as determined by the District unless otherwise required by law.

2) In the event of death of the retiree, his or her spouse will be eligible to the above credits on the above basis as if the retiree was still living through the eligibility period reflected in this benefit offering had the employee survived.

3) There is no cash equivalency benefit available under this provision for the retiree or any surviving spouse.

For Staff hired after July 1, 2004, yet prior to July 1, 2009.

Upon retirement, for an eligible teacher whose application has been approved, the District will credit up to three thousand dollars for each year of service (\$3,000 x years of service at the Colby School District, up to a maximum of \$50,000) for the retiree for a premium only health reimbursement account (HRA) until the teacher becomes entitled to Medicare.

1) Each qualifying teacher shall have \$3,000, or such amount as proportional to the employment status of the teacher pursuant to his/her letter of appointment, designated in an HRA (Health Retirement Account) to be used for health insurance premiums upon retirement. The HRA may be funded or unfunded as determined by the District unless otherwise required by law.

2) In the event of death of the retiree, his or her spouse will be eligible to the above credits on the above basis as if the retiree was still living through the eligibility period reflected in this benefit offering had the employee survived.

3) There is no cash equivalency benefit available under this provision for the retiree or any surviving spouse.

For Staff hired after July 1, 2009, yet prior to July 1, 2013.

Upon retirement, for an eligible teacher whose application has been approved, the District will credit up to three thousand dollars for each year of service (\$3,000 x years of service at the Colby School District, up to a maximum of \$25,000) for the retiree for a premium only health reimbursement account (HRA) until the teacher becomes entitled to Medicare.

1) Each qualifying teacher shall have \$3,000, or such amount as proportional to the employment status of the teacher pursuant to his/her letter of appointment, designated in an HRA (Health Retirement Account) to be used for health insurance premiums upon retirement. The HRA may be funded or unfunded as determined by the District unless otherwise required by law.

2) In the event of death of the retiree, his or her spouse will be eligible to the above credits on the above basis as if the retiree was still living through the eligibility period reflected in this benefit offering had the employee survived.

3) There is no cash equivalency benefit available under this provision for the retiree or any surviving spouse.

For Staff hired after July 1, 2013.

Upon employment, for an eligible teacher, the District will contribute \$500 annually (each year of service) to a premium only health reimbursement account (HRA) for utilization upon retirement from the Colby School District.

D. Payment of Benefit

1a) For Staff hired prior to July 1, 1986

Upon Board approval of the retirement date, a monthly benefit is determined by dividing the total benefit credit by the number of months until the employee becomes entitled to Medicare eligibility.

1b) For Staff hired prior to July 1, 2013

Upon Board approval of the retirement date, an annual benefit is determined by dividing the total benefit credit by 5.

2) Retired employees may use the HRA credit for premium only health reimbursement account from a third party vendor selected by the district.

3) Retired employees who return to work in any position which offers health insurance shall have their benefit suspended until they no longer work in a position that is eligible for health insurance, subject to the terms for participation eligibility.

Upon termination of any health insurance qualifying post retirement employment, monthly benefits with the Colby School District will be recalculated as described in Part II, Section 8, D(1a) and D(1b).

4) Decisions made by the District in the interpretation and operation of this benefit offering shall be in its sole discretion and are final and binding. In the event of any review of a decision by a court of law, the reviewing tribunal shall give deference to the District's decision, confirming such decision, unless it is shown that the District acted in an arbitrary and capricious manner. The decision of the District on all issues under this offering shall be final.

D. Calculation of Benefit

1) Hire Date: In instances where there is a break in service, the hire date used to determine the maximum benefit allowed under Section 8 is the most recent date of hire.

2) Years of Service: In instances where there is a break in service, the years of service are the total years of service within the District to determine the maximum benefit allowed under Section 8.

COLBY SCHOOL DISTRICT

Extra Duty Wage Schedule

Carl Perkins Staff Coordinator	\$ 450.00
Chemical Hygiene Coordinator	\$ 652.80
Steering Committee - Elementary, MS, HS	\$ 489.60
Substitute Caller Grades K-4	\$1,575.00
Substitute Caller Grades 5-12	\$2,100.00
Sustainability Coordinator	\$ 652.80
Teacher Mentors	\$ 510.00
Wellness Coordinator	\$ 652.80
Instructional Technology District Coordinator	\$2,500.00
Instructional Technology High School Support	\$1,500.00
Instructional Technology Middle School Support	\$1,500.00
Instructional Technology Elementary Support	\$1,500.00
After School Study Club Coordinator	\$1,000.00
Teacher Overload Assignment	\$1,000/semester
Curriculum Study	\$ 12.50 per hour
Homebound Instruction	\$ 24.00 per hour
Summer School	\$ 24.00 per hour
Teacher Substituting in a Class	\$ 9.00 FOR 1-30 minutes
	\$ 18.00 for 31-60 minutes
Volunteer Assignment During Lunch Period	\$ 18.00 per hour
Event Supervisor (Crowd Control)	\$ 36.00 per event
Ticket Takers, Ticket Sellers, Timers	\$ 27.00 per event
Scorekeepers, Yard Keepers, Down Keepers (per athletic event)	
Chaperones	\$ 20.00 per trip for 0 – 60 miles
(for any approved bus trip at a time other than during regular school hours)	\$ 25.00 per trip for over 60 miles
	\$ 50.00 for any overnight trip**

**** Does not apply to advisors/coaches already compensated through extra-curricular Letters of Appointment.**